

TECHNICAL MANUAL

UNIT, DIRECT SUPPORT AND GENERAL SUPPORT
MAINTENANCE

REPAIR PARTS AND SPECIAL TOOLS LISTS

FOR

SHELTER ELECTRICAL EQUIPMENT

S-280C/G UNSHIELDED

(NSN: 5411-01-092-0892)

S-280C/G SHIELDED

(NSN: 5411-01-304-3069)

Approved for public release; distribution is unlimited.

HEADQUARTERS, DEPARTMENT OF THE ARMY
19 AUGUST 1991

**CHANGE
NO.1**

HEADQUARTERS
DEPARTMENT OF THE ARMY
WASHINGTON, D.C., 15 AUGUST 1997

Unit, Direct Support And General Support Maintenance
Repair Parts And Special Tools Lists
For

**SHELTER, ELECTRICAL EQUIPMENT
S-280C/G (Unshielded) NSN 5411-01-092-0892
S-280C/G (Shielded) NSN 5411-01-304-3069**

DISTRIBUTION STATEMENT A: Approved for public release; distribution is unlimited.

TM 10-5411-207-24P, 19 August 1991, is changed as follows:

1. Title is changed as shown above.
2. Remove and insert pages as indicated below. New or changed text material is indicated by a vertical bar in the margin. An illustration change is indicated by a miniature pointing hand.

Remove pages	Insert Pages
i/(ii blank)	i/(ii blank)
1 and 2	1 and 2
5 and 6	5 and 6
1-1 and 1-2	1-1 and 1-2
Figure 2 (sh 1 of 2)/ Figure 2 (sh 2 of 2)	Figure 2 (sh 1 of 2)/ Figure 2(sh 2 of 2)
2-1 and Figure 3	2-1 and Figure 3
3-1 and Figure 4	3-1 and Figure 4
10-1/(10-2 blank)	10-1/(10-2 blank)
I-1 thru I-8	I-1 thru I-8
I-9/(I-10 blank)	I-9/(I-10 blank)
Cover	Cover

3. Retain this sheet in front of manual for reference purposes.

TM 10-5411-207-24P

C1

By Order of the Secretary of the Army:

Official:

JOEL B. HUDSON
*Administrative Assistant to the
Secretary of the Army*
03884

DENNIS J. REIMER
*General, United States Army
Chief of Staff*

DISTRIBUTION:

To be distributed in accordance with DA Form 12-25-E, block no. 2745, requirements for
TM 10-5411-207-24P

**Unit, Direct Support and General Support Maintenance
Repair Parts and Special Tools Lists
For**

**SHELTER ELECTRICAL EQUIPMENT
S-280C/G UNSHIELDED
(NSN: 5411-01-092-0892)
S-280C/G SHIELDED
(NSN: 5411-01-304-3069)**

current as of 16 October 1995

REPORTING ERRORS AND RECOMMENDING IMPROVEMENTS

You can help improve this manual. If you find any mistakes or if you know of a way to improve the procedures please let us know. Mail your letter, DA Form 2028 (Recommended Changes to Publications and Blank Forms), or DA Form 2028-2 located in the back of this manual directly to: U.S. Army Aviation and Troop Command, ATTN: AMSAT-I-MP, 4300 Goodfellow Boulevard, St. Louis, Mo 63120-1798. A reply will be furnished directly to you.

Approved for public release; distribution is unlimited

TABLE OF CONTENTS

		Page	Illus Figure
SECTION I.	INTRODUCTION	1	
	II. REPAIR PARTS LIST		
Group 00	Shelter, Electrical Equipment S-280C/G	1-1	1
	01 Door Assembly and Emergency Exit Panel	2-1	2
	02 Door Latch Assembly	3-1	3
	03 Keeper Assembly	4-1	4
	04 Door Brace Assembly	5-1	5
	05 Pan Assembly Recessed Step	6-1	6
	06 Towing Eye Assembly	7-1	7
	07 Lifting and Tiedown Eye Assembly	8-1	8
	08 Skid Assembly	9-1	9
	09 Hold Down Assembly	10-1	10
SECTION III.	Special Tools List (Not Applicable)		
IV.	National Stock Number and Part Number Index	I-1	

**UNIT, DIRECT SUPPORT
AND GENERAL SUPPORT
MAINTENANCE REPAIR PARTS AND SPECIAL TOOLS LIST**

SECTION I. INTRODUCTION

1. **SCOPE.** This RPSTL lists and authorizes spares and repair parts; special tools; special test, measurement and diagnostic equipment (TMDE); and other special support equipment required for performance of unit, direct support, and general support maintenance of the S-280C/G Unshielded and S-280C/G Shielded shelters. It authorizes the requisitioning, issuing, and disposition of spares, repair parts and special tools as indicated by the source, maintenance and recoverability (SMR) codes.

2. **GENERAL.** In addition to this section, Introduction, this Repair Parts and Special Tools List is divided into the following sections:

a. **Section II. Repair Parts List.** A list of spares and repair parts authorized by this RPSTL for use in the performance of maintenance. The list also includes parts which must be removed for replacement of the authorized parts. Parts lists are composed of functional groups in ascending alphanumeric sequence, with the parts in each group listed in ascending figure and item number sequence. Bulk materials are listed in item name sequence. Repair parts kits are listed separately in their own functional group within Section II. Repair parts for repairable special tools are also listed in this section. Items listed are shown on the associated illustration(s)/figure(s).

b. **Section III. Special Tools List.** A list of special tools, TMDE, and other special support equipment authorized by this RPSTL (as indicated by Basis of Issue (BOI) information in DESCRIPTION AND USABLE ON CODE column) for the performance of maintenance.

c. **Section IV. Cross-references Indexes.** A list, in National Item Identification Number (NIIN) sequence, of all National stock numbered items appearing in the listing, followed by a list in alphanumeric sequence of all part numbers appearing in the listings. National stock numbers and part numbers are cross referenced to each illustration figure and item number appearance. The figure and item number index lists figure and item number in alphanumeric sequence and cross references NSN, CAGEC and part number.

3. **EXPLANATION OF COLUMNS (SECTIONS II AND III).**

a. **ITEM NO. (Column (1)).** Indicates the number used to identify items called out in the illustration.

b. **SMR Code (Column (2)).** The Source, Maintenance, and Recoverability (SMR) code is a 5-position code containing supply/requisitioning information, maintenance category authorization criteria, and disposition instruction, as shown in the following breakout:

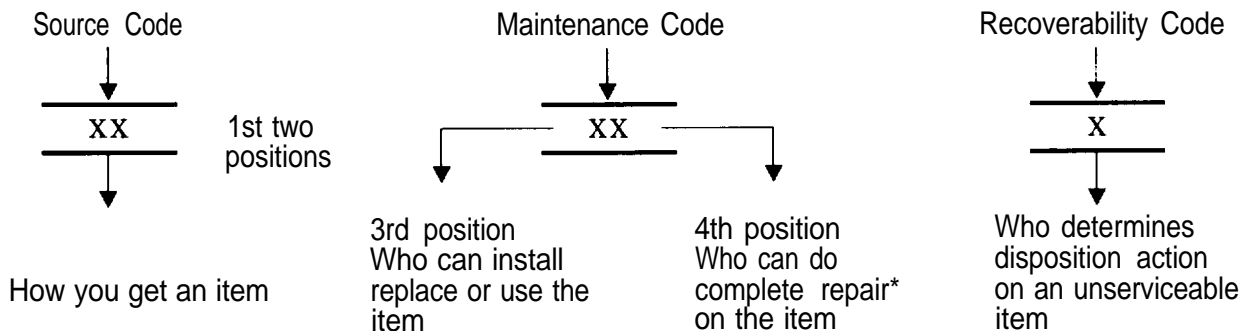

*Complete Repair: Maintenance capacity, capability, and authority to perform all corrective maintenance tasks of the "Repair" function in a use/user environment in order to restore serviceability to a failed item.

(1) **Source Code.** The source code tells you how to get an item needed for maintenance, repair, or overhaul of an end item/equipment. Explanations of source codes follows:

Code	Explanation
PA PB PC** PD PE PF PG	} Stocked items; use the applicable NSN to request/requisition items with these source codes. They are authorized to the category indicated by the code entered in the 3rd position of the SMR code. } **NOTE: Items coded PC are subject to deterioration.
KD KF KB	} Items with these codes are not to be requested/requisitioned individually. They are part of a kit which is authorized to the maintenance category indicated in the 3rd position of the SMR code. The complete kit must be requisitioned and applied.
M O - (Made at unit AVUM Level) M F - (Made at DS/AVUM Level) M H - (Made at GS Level) M L - (Made at Specialized Repair Activity (SRA)) M D - (Made at Depot)	} Items with these codes are not to be requested/requisitioned individually. They must be made from bulk material which is identified by the part number in the DESCRIPTION and USABLE ON CODE (UOC) column and listed in the Bulk Material group of the repair parts list in this RPSTL. If the item is authorized to you by the 3rd position code of the SMR code, but the source code indicates it is made at a higher level, order the item from the higher level of maintenance.
A O - (Assembled by unit/AVUM Level) A F - (Assembled by DS/AVIM Level) A H - (Assembled by GS Category) A L - (Assembled by SRA) A D - (Assembled by Depot)	} Items with these codes are not to be requested/requisitioned individually. The parts that make up the assembled item must be requisitioned or fabricated and assembled at the level of maintenance indicated by the source code. If the 3rd position code of the SMR code authorized you to replace the item, but the source code indicated the items are assembled at a higher level, order the item from the higher level of maintenance.
X A - Do not requisition "XA"-coded item. Order its next higher assembly. (Also, refer to the NOTE below.) X B - If an "XB" item is not available from salvage, order it using the CAGEC and part number given. X C - Installation drawing, diagram, instruction sheet, field service drawing, that is identified by manufacturer's part number. X D - Item is not stocked. Order an "XD"-coded item through normal supply channels using the CAGEC and part number given if no NSN is available.	

NOTE

Cannibalization or controlled exchange, when authorized, may be used as a source of supply for items with the above source codes, except for those source coded "XA" or those aircraft support items restricted by requirements of AR 750-1.

(2) Maintenance Code. Maintenance codes tell you the level(s) of maintenance authorized to USE and REPAIR support items. The maintenance codes are entered in the third and fourth positions of the SMR code as follows:

(a) The maintenance code entered in the third position tells you the lowest maintenance level authorized to remove, replace, and use an item. The maintenance code entered in the third position will indicate authorization to one of the following levels of maintenance.

Code	Application/Explanation
C	- Crew or operator maintenance done within organizational or aviation unit maintenance.
O	- Unit or aviation unit category can remove, replace, and use the item.
F	- Direct support or aviation intermediate level can remove, replace, and use the item.
H	- General support level can remove, replace, and use the item.
L	- Specialized repair activity can remove, replace, and use the item.
D	- Depot level can remove, replace, and use the item.

(b) The maintenance code entered in the fourth position tells whether or not the item is to be repaired and identifies the lowest maintenance level with the capability to do complete repair (i.e., perform all authorized repair functions.) NOTE: Some limited repair may be done on the item at a lower level of maintenance, if authorized by the Maintenance Allocation Chart (MAC) and SMR codes. This position will contain one of the following maintenance codes.

Code	Application/Explanation
O	- Unit or (aviation unit) is the lowest level that can do complete repair of the item.
F	- Direct support or aviation intermediate is the lowest level that can do complete repair of the item.
H	- General Support is the lowest level that can do complete repair of the item.
L	- Specialized repair activity is the lowest level that can do complete repair of the item.
D	- Depot is the lowest level that can do complete repair of the item.
Z	- Nonreparable. No repair is authorized.
B	- No repair is authorized. (No parts or special tools are authorized for the maintenance of a "B" coded item). However, the item may be reconditioned by adjusting, lubricating, etc., at the user level.

(3) Recoverability Code. Recoverability codes are assigned to items to indicate the disposition action on unserviceable items. The recoverability code is entered in the fifth position of the SMR Code as follows:

Recoverability Codes	Application/Explanation
Z	- Nonreparable item. When unserviceable, condemn and dispose of the item at the level of maintenance shown in third position of SMR Code.

TM 10-5411-207-24P

- O - Reparable item. When not economically repairable, condemn and dispose of the item at organizational or aviation unit level
- F - Reparable item. When uneconomically repairable, condemn and dispose of the item at the direct support or aviation intermediate level
- H - Reparable item. When uneconomically repairable, condemn and dispose of the item at the general support level.
- D - Reparable item. When beyond lower level repair capability, return to depot. Condemnation and disposal of item not authorized below depot level.
- L - Reparable item, Condemnation and disposal not authorized below specialized repair activity (SRA).
- A - Item requires special handling or condemnation procedures because of specific reasons (e.g., precious metal content, high dollar value, critical material, or hazardous material). Refer to appropriate manuals/directives for specific instructions.

c. CAGEC (Column (3)). The Commercial and Government Entity Code (CAGEC) is a 5-digit numeric code which is used to identify the manufacturer, distributor, or Government agency, etc., that supplies the item.

d. PART NUMBER (Column (4)). Indicates the primary number used by the manufacturer, (individual, company, firm, corporation, or Government activity), which controls the design and characteristics of the item by means of its engineering drawings, specifications standards, and inspection requirements to identify an item or range of items.

NOTE

When you use an NSN to requisition an item, the item you receive may have a different part number from the part ordered.

e. DESCRIPTION AND USABLE ON CODE (UOC) (Column (5)). This column includes the following information:

- (1) The Federal item name and, when required, a minimum description to identify the item.
- (2) The physical security classification of the item is indicated by the parenthetical entry, e.g., PhySec C1 - Confidential, Phy Sec C1 (S) - Secret, Phy Sec C1 (T) - Top Secret.
- (3) Items that are included in kits and sets are listed below the name of the kit or set.
- (4) Spare/repair parts that make up an assembled item are listed immediately following the assembled item line entry.
- (5) Part numbers for bulk materials are referenced in this column in the line item entry for the item to be manufactured/fabricated.
- (6) When the item is not used with all serial numbers of the same model, the effective serial numbers are shown on the last line(s) of the description (before UOC) .
- (7) The usable on code, when applicable (see paragraph 5, Special Information).
- (8) In the Special Tools List section, the basis of issue (BOI) appears as the last line(s) in the entry for each special tool, special TMDE, and other special support equipment. When density of equipments

supported exceeds density spread indicated in the basis of issue, the total authorization is increased proportionately.

(9) The statement "END OF FIGURE" appears just below the last item description in Column 5 for a given figure in both Section II and Section III.

(10) The indenture, shown as dots appearing before the repair part, indicates that the item is a repair part of the next higher assembly.

f. **QTY (Column (6)).** The QTY (quantity per figure column) indicates the quantity of the item used in the breakout shown on the illustration figure, which is prepared for a functional group, subfunctional group, or an assembly. A "V" appearing in this column in lieu of a quantity indicates that the quantity is variable and may vary from application to application.

4. EXPLANATION OF COLUMNS (SECTION IV).

a. NATIONAL STOCK NUMBER (NSN) INDEX.

(1) **STOCK NUMBER column.** This column lists the NSN by National item identification number (NIIN) sequence. The NIIN consists of the last nine digits of the NSN, i.e.

NSN
<hr style="width: 100%;"/>
5305-01-574-1467
<hr style="width: 100%;"/>
NIIN

When using this column to locate an item, ignore the first 4 digits of the NSN. However, the complete NSN should be use when ordering items by stock number.

(2) **FIG. column.** This column lists the number of the figure where the item is identified/located. The figures are in numerical order in Section II and Section III.

(3) **ITEM column.** The item number identifies the item associated with the figure listed in the adjacent FIG. column. This item is also identified by the NSN listed on the same line.

b. **PART NUMBER INDEX.** Part numbers in this index are listed by part number in ascending alphanumeric sequence. (i.e., vertical arrangement of letter and number combination which places the first letter or digit of each group in order A through Z, followed by the numbers 0 through 9 and each following letter or digit in like order).

(1) **CAGEC column.** The Commercial and Government Entity Code (CAGEC) is a 5-digit numeric code used to identify the manufacturer, distributor, or Government agency, etc., that supplies the item.

(2) **PART NUMBER column.** Indicates the primary number used by the manufacturer (individual. firm. corporation or Government activity), which controls the design and characteristics of the item by means of its engineering drawings, specifications. standards, and inspection requirements to identify an item or range of items.

(3) **STOCK NUMBER column.** This column lists the NSN for the associated part number and manufacturer identified in the PART NUMBER and CAGEC columns to the left.

(4) **FIG. column.** This column lists the number of the figure where the item is identified/located in Sections II and III.

(5) **ITEM column.** The item number is that number assigned to the item as it appears in the figure referenced in the adjacent figure number column.

c. FIGURE AND ITEM NUMBER INDEX.

(1) **FIG. column.** This column lists the number of the figure where the item is identified/located in Section II and III.

(2) **ITEM column.** The item number is that number assigned to the item as it appears in the figure referenced in the adjacent figure number column.

(3) **STOCK NUMBER column.** This column lists the NSN for the item.

(4) **CAGEC column.** The Commercial and Government Entity Code (CAGEC) is a 5-digit numeric code used to identify the manufacturer, distributor, or Government agency, etc., that supplies the item.

(5) **PART NUMBER column.** Indicates the primary number used by the manufacturer (individual, firm, corporation, or Government activity), which controls the design and Characteristics of the item by means of its engineering drawings, specifications, standards, and inspection requirements to identify an item or range of items.

5. SPECIAL INFORMATION.

a. USABLE ON CODE. The usable on code appears in the lower corner of the Description column heading. Usable on codes are shown as "UOC" in the Description Column (justified left) on the last line applicable to the item description/nomenclature. Uncoded items are applicable to all models.

b. ASSOCIATED PUBLICATIONS. The publications listed below pertain to the S-280C/G Unshielded and S-280C/G Shielded shelters and their components.

Publication	Short Title
TM 10-5411-207-14	Shelter, Electrical Equipment S-280C/G Unshielded and S-280C/G Shielded

6. HOW TO LOCATE REPAIR PARTS.

a. When National Stock Number or Part Number is NOT Known.

(1) **First.** Using the table of contents, determine the assembly group or subassembly group to which the item belongs. This is necessary since figures are prepared for assembly groups and subassembly groups, and listings are divided into the same groups.

(2) **Second.** Find the figure covering the assembly group or subassembly group to which the item belongs.

(3) **Third.** Identify the item on the figure and note the item number.

(4) **Fourth.** Refer to the Repair Parts List for the figure to find the part number for the item number noted on the figure.

(5) **Fifth.** Refer to the Part Number Index to find the NSN, if assigned.

b. When National Stock Number or Part Number IS Known.

(1) **First.** Using the Index of National Stock Numbers and Part Numbers, find the pertinent National Stock Number or Part Number. The NSN index is in National Item Identification Number (NIIN) sequence (see c-4a.(1)). The part numbers in the Part Number index are listed in ascending alphanumeric sequence (see paragraph c-4.b). Both indexes cross-reference you to the illustration figure and item number of the item you are looking for.

(2) Second. After finding the figure and item number, verify that the item is the one you are looking for, then locate the item number in the repair parts list for the figure.

7. **ABBREVIATIONS.** Abbreviations used in this manual are listed in MIL-STD-12.

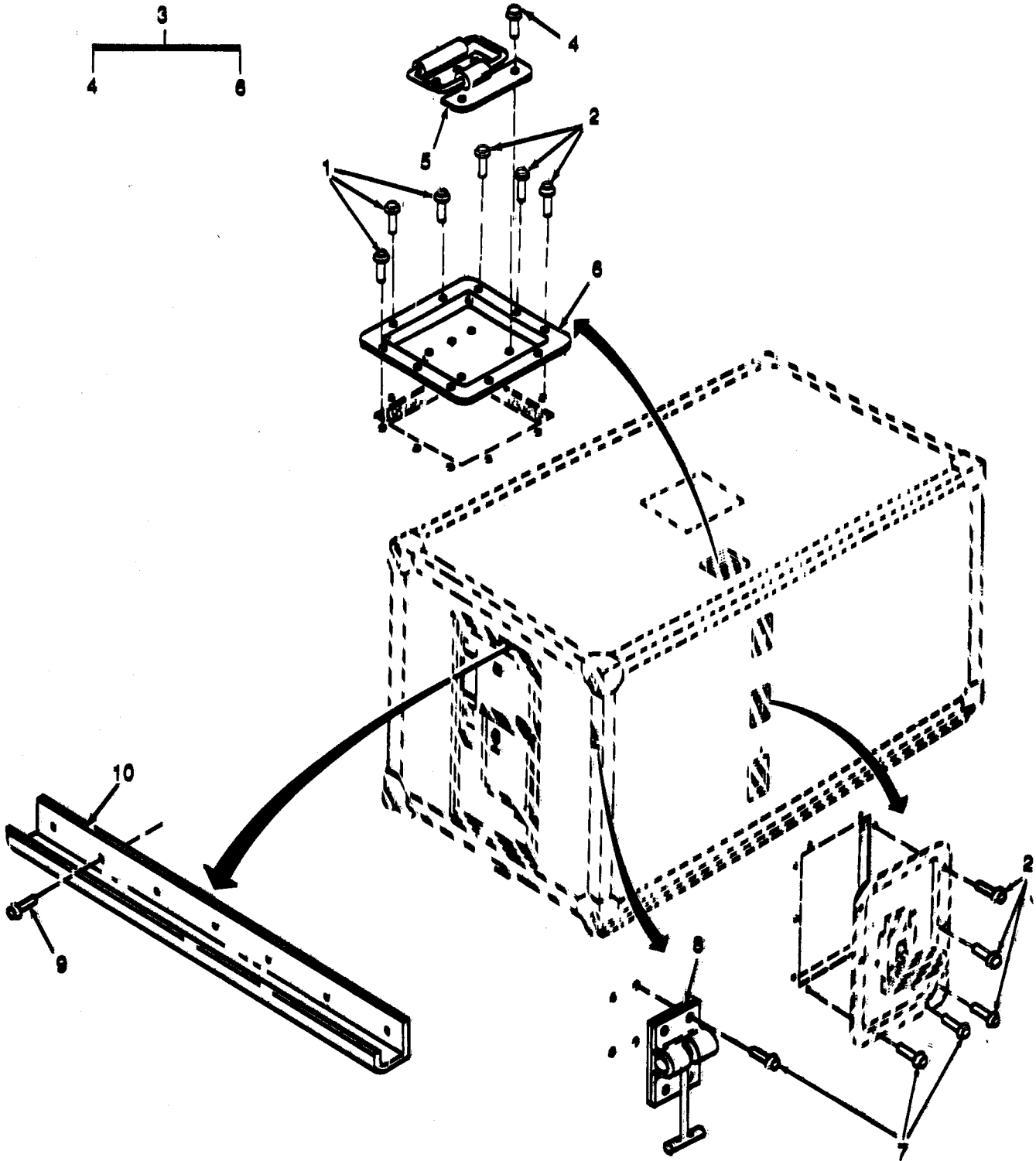

Figure 1. Shelter, Electrical Equipment S-280C/G (Sheet 1 of 3)

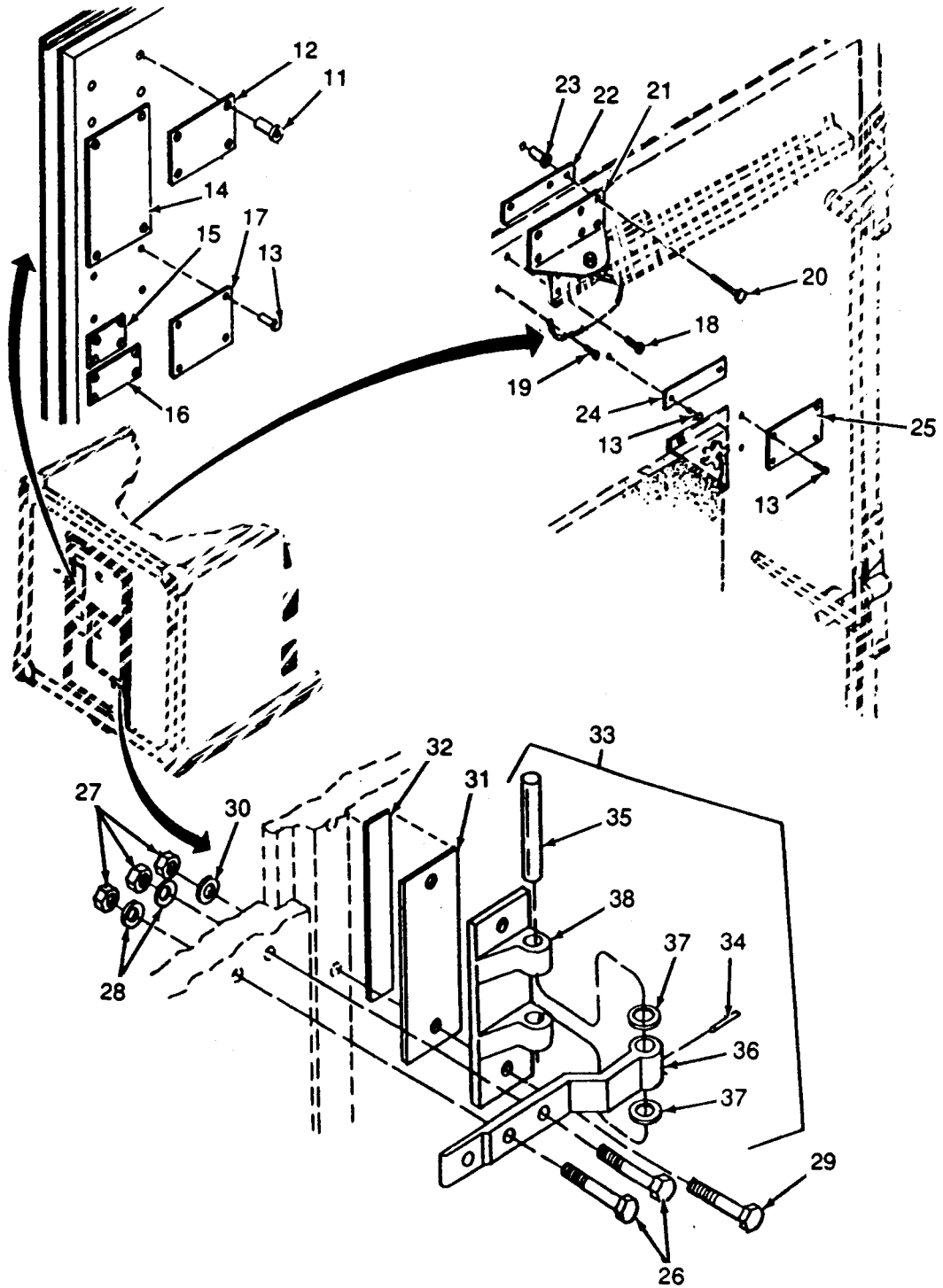

Figure 1. Shelter, Electrical Equipment S-280C/G (Sheet 2 of 3)

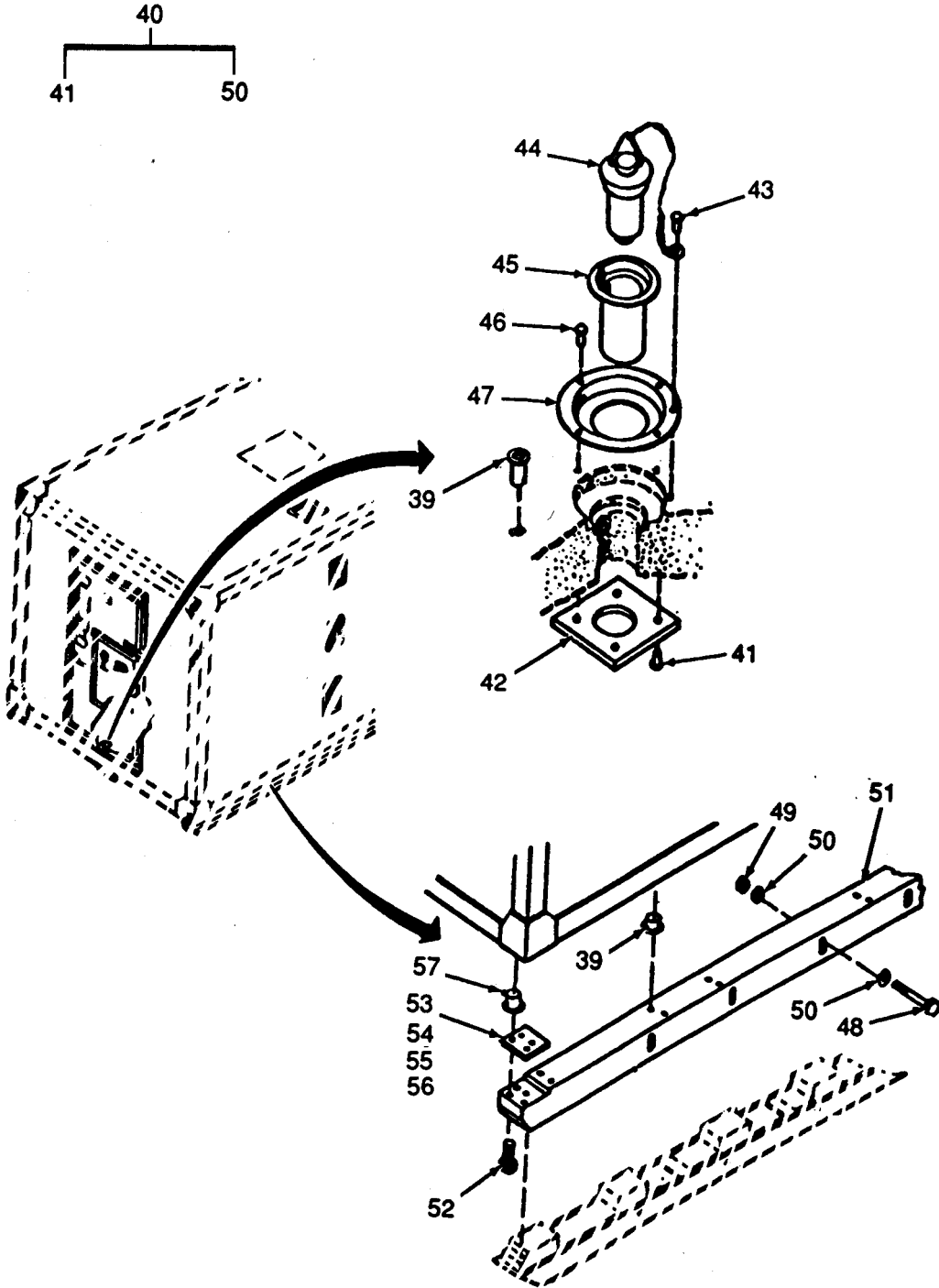

Figure 1. Shelter, Electrical Equipment S-280C/G (Sheet 3 of 3)

SECTION II			TM10-5411-207-240 CO1		
(1)	(2)	(3)	(4)	(5)	(6)
ITEM	SMR		PART		
NO	CODE	CAGEC	NUMBER	DESCRIPTION	AND USABLE ON CODES(UOC) QTY
GROUP 00 SHELTER, ELECTRICAL					
EQUIPMENT S-280C/G					
FIG.1 SHELTER, ELECTRICAL					
EQUIPMENT S-280C/G					
1	PAOZZ	07707	AD62H	RIVET,BLIND	7
2	PAOZZ	07707	AD68H	RIVET,BLIND	12
3	PAOZZ	80063	SM-C-165382	HANDHOLD ASSEMBLY	1
4	PAOZZ	96906	MS20470AD6-8	.RIVET,SOLID	5
5	PAOZZ	98003	H-945-SS-2-RG	.HANDLE,BAIL	1
6	XBOZZ	81337	SM-C-165383	.PAN, HAND HOLD	1
7	PAOZZ	07707	AD64H	RIVET, BLIND	25
8	PAOZZ	19220	AL5601 1/2-51	T-LATCH ASSY	1
9	PAOZZ	07707	AD45H	RIVET,BLIND	7
10	PAOZZ	81337	SM-B-947164	DRIP MOULDING, DOOR	1
11	PAOZZ	03481	SS8B120	NUT, PLAIN, BLIND RIV	7
12	XBOZZ	81337	SM-B-947228	PLATE, DATA, AIRCRAFT	1
13	PAOZZ	07707	AD42H	RIVET, BLIND	16
14	XBOZZ	81337	SM-C-165466	PLATE, TRANSPORT	1
15	XBOZZ	81337	SM-B-947229	NAMEPLATE	1
				UOC: ESF	
* 15	XBOZZ	81337	SC-B-595079	NAMEPLATE	1
				UOC: FLE	
16	XBOZZ	81337	SM-B-340031	PLATE, AIRBORNE INST	1
17	XBOZZ	81337	SM-B-947239	PLATE, PAINT INSTR	1
18	PAOZZ	96906	MS24617-54	SCREW, TAPPING, THREA	10
19	PAOZZ	96906	MS35493-53	SCREW, WOOD	1
20	PAOZZ	88044	AN101011	BOLT, MACHINE	6
21	PAOZZ	80063	SC-C-200135	BRACKET, ANGLE	1
22	PAOZZ	81337	SM-B-947231	SHIM	1
23	PAOZZ	96906	MS35914-150	INSERT, SCREW THREAD	6
24	XBOZZ	81337	SM-C-564811	PLATE, INSTRUCTION	1
25	XBOZZ	81337	SM-B-615256	SEC EXIT, DATA PLATE	1
26	PAOZZ	88044	AN5C-26A	BOLT, MACHINE	8
27	PAOZZ	96906	MS21042-5	NUT, SELF-LOCKING, EX	16
28	PAOZZ	96906	MS15795-812	WASHER, FLAT	8
29	PAOZZ	88044	AN5C-25A	BOLT, MACHINE	8
30	PAOZZ	81352	AN960-C516L	WASHER, FLAT	8
31	PAOZZ	81337	SM-B-162197-2	SHIM	V
32	PAOZZ	81337	SM-B-947146-3	SHIM	V
33	PAOZZ	81337	SM-C-317057	HINGE ASSEMBLY	4
34	PAOZZ	96906	MS16562-237	. PIN, SPRING	1
35	PAOZZ	81337	SM-B-508785	.PIN, HINGE	1
36	PAOZZ	81337	SM-C-508783	.BODY, HINGE	1
37	PAOZZ	81337	SM-B-317129	.WASHER, HINGE	2
38	PAOZZ	81337	SM-C-508784	.BUTT PLATE, HINGE	1
39	PAOZZ	03481	S31B425CS1	NUT, BLIND RIVET	37
40	PAOZZ	81337	SM-D-947154	DRAIN INSTALLATION	1
41	PAOZZ	07707	AD43H	.RIVET, BLIND	4
42	XBOZZ	81337	SM-C-947155	.PLATE	1
43	PAOZZ	07707	AD64H	.RIVET, BLIND	1

SECTION II			TM10-5411-207-24P CO1		
(1)	(2)	(3)	(4)	(5)	(6)
ITEM	SMR		PART		
NO	CODE	CAGEC	NUMBER	DESCRIPTION AND USABLE ON CODES (UOC)	QTY
44	PAOZZ	01943	8173-1	PLUG WITH CHAIN	1
45	XAOZZ	81337	SM-B-947157	.TUBE	1
46	PAFZZ	07707	AD42S	.RIVET, BLIND	4
47	XAOZZ	81337	SM-C-947156	.PAN, DRAIN	1
48	PAOZZ	96906	MS16208-68	BOLT, MACHINE	18
49	PAOZZ	96906	MS17830-6C	NUT, SELF-LOCKING, HE	36
50	PAOZZ	96906	MS15795-815	WASHER, FLAT	3
50	XBOZZ	81337	SM-D-947235	MTG BRACKET, SKID	24
52	PAOZZ	70276	56517	SCREW	V
53	PBOZZ	81337	SM-C-947169-1	SHIM	V
54	PAOZZ	81337	SM-C-947169-2	SHIM	V
55	PAOZZ	81337	SM-C-947169-3	SHIM	V
56	PAOZZ	81337	SM-C-947169-4	SHIM	V
57	PAOZZ	96906	S31B125CS1	NUT, BLIND RIVET	24

END OF FIGURE

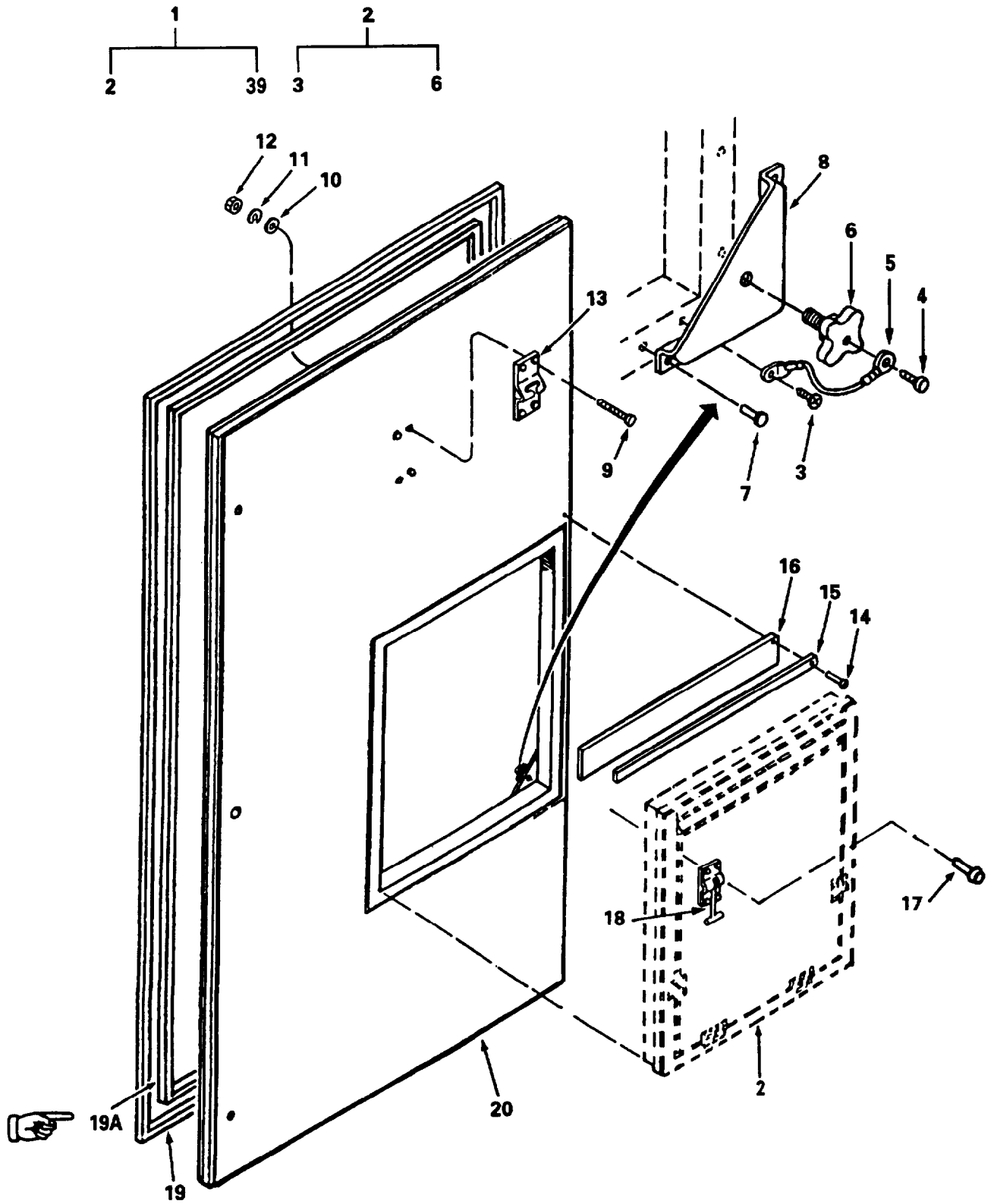

Figure 2. Door Assembly and Emergency Exit Panel (Sheet 1 of 2)

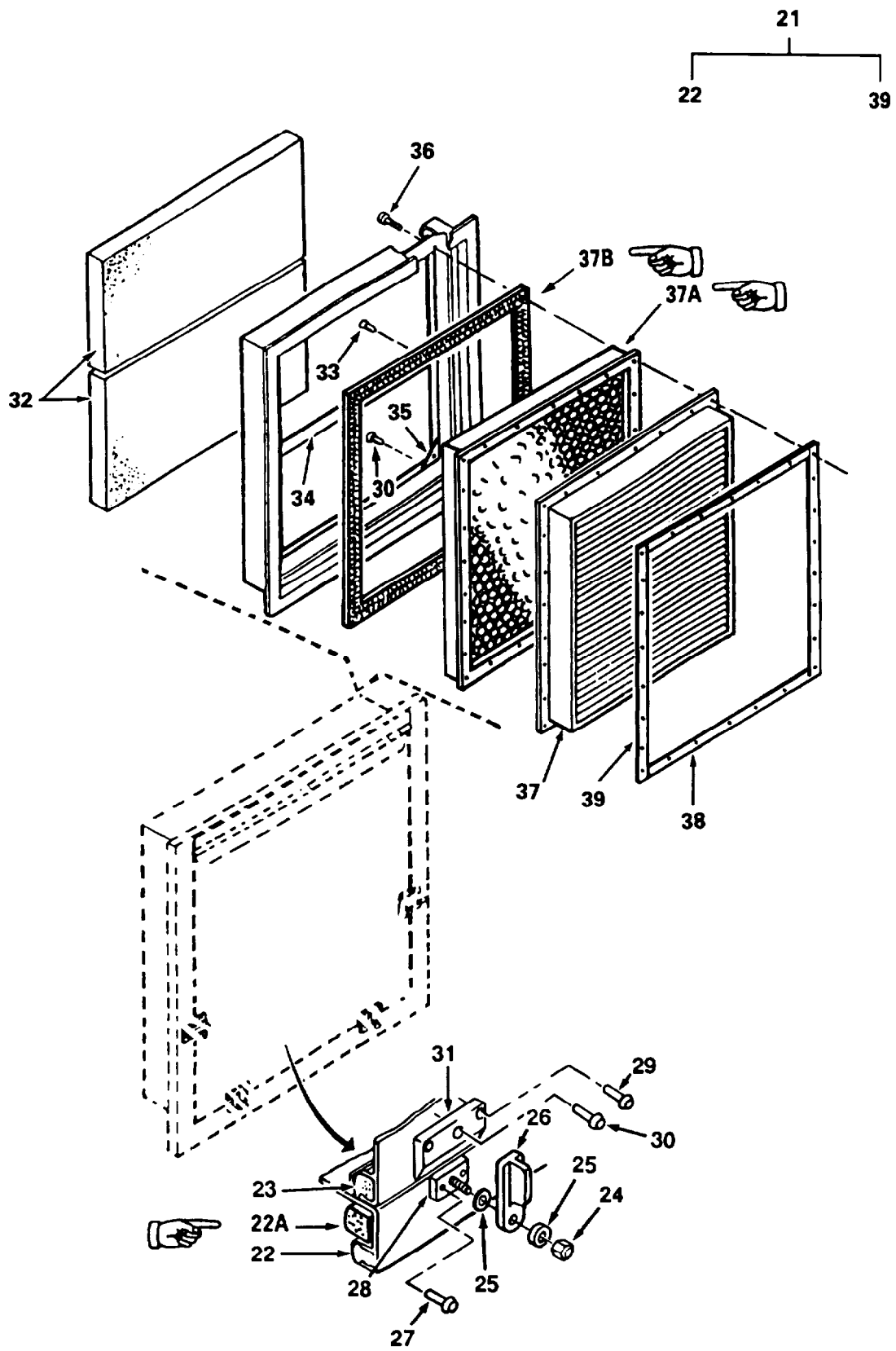

Figure 2. Door Assembly and Emergency Exit Panel (Sheet 2 of 2)

SECTION II			TM10-5411-207-24P CO1			
(1)	(2)	(3)	(4)	(5)	(6)	
ITEM	SMR		PART			
NO	CODE	CAGEC	NUMBER	DESCRIPTION AND USABLE ON CODES (UOC)	QTY	
GROUP 01 DOOR ASSEMBLY AND EMERGENCY EXIT PANEL						
FIG.2 DOOR ASSEMBLY AND EMERGENCY EXIT PANEL						
1	PFOOO	81337	SM-D-947166	DOOR ASSEMBLY	1	
2	PAO00	81337	SM-C-450441	.KNOB ASSY	1	
3	PAOZZ	70892	13AN	..FASTNER, BEAD CHAIN	1	
4	PAOZZ	96906	MS21318-46	..SCREW, DRIVE	1	
5	PAOZZ	70892	13S	..CHAIN, BEAD	1	
6	PAOZZ	81337	SM-C-615263	..KNOB, CASTING	1	
7	PAOZZ	80205	NAS1398D6-8	. RIVET, BLIND	16	
8	PAOZZ	81337	SM-C-450443	. RET, AIR INLET PANEL	4	
9	PAOZZ	96906	MS35206-273	. SCREW, MACHINE	4	
10	PAOZZ	96906	MS27163-8	. WASHER, FLAT	4	
11	PAOZZ	96906	MS35338-43	. WASHER, LOCK	4	
12	PAOZZ	96906	MS35649-202	. NUT, PLAIN, HEXAGON	4	
13	PAOZZ	19220	AL5601 1/2-51	. T-LATCH ASSY	1	
14	PAOZZ	80205	NAS1398D6-3	. RIVET, BLIND	17	
15	PAOZZ	81337	SM-B-450465	. STRIP, DRIP CAP	1	
16	PAOZZ	81337	SM-B-555572	. DRIP CAP	1	
17	XDOZZ	80205	NAS1398D6-5	. RIVET, BLIND	4	
*	18	PAOZZ	19220	AL5601 1/2-50	. HOLDER, DOOR	1
*	19	PAOZZ	81337	SM-C-564839	. GASKET, SILICONE	V
*	19A	MOOZZ	81337	SM-B-564670-3	. SHIELD, EM	1
UOC: FLE						
20	PFOZZ	81337	SM-D-947167	. PANEL ASSY, DOOR	1	
21	PFOOO	81337	SM-D-450462	. PANEL ASSY, EMER	1	
22	MOOZZ	81337	SM-C-564839	..GASKET, SILICONE	1	
*	22A	MOOZZ	81337	SM-B-564670-4	..SHIELD, EM	1
UOC: FLE						
23	MOOZZ	81337	SM-C-564839	..GASKET, SILICONE	1	
24	PAOZZ	72962	21NTU-040	..NUT	4	
25	PAOZZ	02751	1-4-31	..WASHER, FLAT	8	
*	26	PAOZZ	80063	SM-B-450447	..LATCH, RIM	4
27	PAOZZ	80205	NAS1739E4-3	..RIVET, BLIND	8	
28	PAOZZ	81337	SM-B-450448	..STUD PLATE ASSY	4	
29	PAOZZ	80205	NAS1399D4-4	..RIVET, BLIND	8	
30	PAOZZ	80205	NAS1398D4-4	..RIVET, BLIND	12	
31	PAOZZ	81337	SM-B-595081	..STRIKE	4	
32	PAOZZ	80063	SM-C-450466	..PLASTIC SHEET	2	
33	PAOZZ	80205	NAS1398D4-3	..RIVET, BLIND	4	
34	PAOZZ	81337	SM-B-450432	..STRIP, DIVIDER	1	
35	PAOZZ	81337	SM-B-450435	..CORNER, GUSSET	4	
36	PAOZZ	96906	MS51957-45	..SCREW, MACHINE	92	
37	PAOZZ	81337	SM-C-615264	..INTAKE LOUVER ASSY	1	
*	37A	PAOZZ	81337	SM-C-450478	..FILTER - RF	1
UOC: FLE						
*37B	PAOZZ	81337	SM-B-450436-1	..TAPE	1	
UOC: FLE						
38	PAOZZ	81337	SM-C-615262-1	..STRIP, LOUVER RET	2	
39	PAOZZ	81337	SM-C-615262-2	..STRIP, LOUVER RET	2	

END OF FIGURE

SECTION II			TM10-5411-207-24P CO1			
(1)	(2)	(3)	(4)	(5)	(6)	
ITEM	SMR		PART			
NO	CODE	CAGEC	NUMBER	DESCRIPTION AND USABLE ON CODES (UOC)	QTY	
GROUP 02 ROLLER LATCH ASSEMBLY						
FIG.3 DOOR LATCH INSTALLATION						
1	PA000	81337	SC-D-200140	DOOR LATCH ASSY	1	
2	PAOZZ	96906	MS171526	.PIN	3	
3	PAOZZ	88044	AN960C616L	.WASHER, FLAT	4	
4	PAOZZ	96906	MS20392-5C33	.PIN, STRAIGHT, HEADED	1	
5	PAOZZ	81337	SC-D-563202GR11	.LATCH ROD ASSY	1	
*	6	PAOZZ	80063	SC-D-563202GRI	.ROD, SPECIAL	1
	7	PAOZZ	96906	MS171659	.PIN, SPRING	1
*	8	PAOZZ	80063	SM-B-113596-1	.HANDLE, DOOR	1
	9	PAOZZ	96906	MS35674-41	.PIN, GROOVED, HEADLES	1
*	10	PAOZZ	80063	SC-C-200141	.LATCH ARM ASSEMBLY	3
	11	XAOZZ	96906	MS171528	..PIN, SPRING	1
	12	XAOZZ	81337	SC-B-200143	..ROLLERLATCH	1
	13	XAOZZ	81337	SC-B-200144	..ROLLER EXTENSION	1
	14	XAOZZ	81337	SC-C-200142	..ARM, LATCH	1
*	15	PAOZZ	80063	SM-C-113597	.HANDLE, DOOR	1
	16	PAOZZ	96906	MS29513-115	..PACKING,PREFORMED	1
	17	PAOZZ	81337	SC-B-200150	.NUT, BEARING SLEEVE	1
	18	PAOZZ	81337	SC-B-200151	.SLEEVE, HANDLE SHAFT	1
	19	PAOZZ	96906	MS20392-5C23	.PIN, STRAIGHT, HEADED	2
	20	PAOZZ	96906	MS17830-10C	.NUT, SELF-LOCKING, HE	2
*	21	PAOZZ	80063	SC-B-200146	.WASHER, FLAT	2
*	22	PAOZZ	80063	SC-B-200145	.SPACER, SLEEVE	2
	23	PAOZZ	81337	SM-B-615259-2	.SPACER	1
	24	PAOZZ	80063	SC-B-595073	.DETENT	1
	25	PAOZZ	81337	SC-D-200140-8	.WASHER, SHIM	2
	26	PAOZZ	80063	SM-B-615259-1	.SPACER, PLATE	2
	27	PAOZZ	81337	SM-B-162200	.BOLT, CARRIAGE	2
	28	PAOZZ	96906	MS51957-64	.SCREW, MACHINE	1
	29	PAOZZ	96906	MS35338-157	.WASHER, LOCK	1
	30	PAOZZ	80063	SC-C-595537	.PADLOCK	1
	31	XBOZZ	81337	SM-C-615255	.ESCUTCHEON PLATE	1
	32	PAOZZ	96906	MS35493-53	.SCREW, WOOD	2
	33	PAOZZ	96906	MS35914-149	.INSERT, SCREW THREAD	1

END OF FIGURE

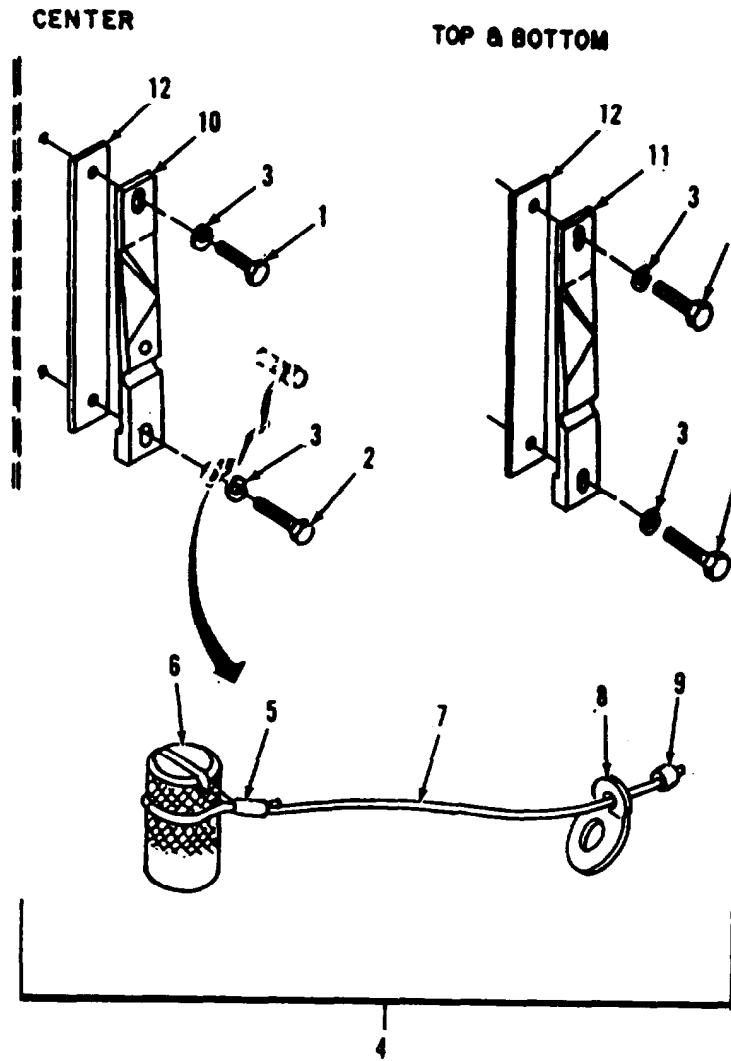

Figure 4. Keeper Assembly

SECTION II				TM10-5411-207-24P	
(1)	(2)	(3)	(4)	(5)	(6)
ITEM	SMR		PART		
NO	CODE	CAGEC	NUMBER	DESCRIPTION AND USABLE ON CODES (UOC)	QTY
GROUP 03 KEEPER ASSEMBLY					
FIG. 4 KEEPER ASSEMBLY					
1	PAOZZ	96906	MS35307-308	.SCREW,CAP,HEXAGON H	3
2	PAOZZ	96906	MS35307-307	.SCREW,CAP,HEXAGON H	3
3	PAOZZ	96906	MS35338-158	.WASHER,LOCK	6
4	PAOZZ	81337	SC-B-781197	.LATCH LOCK ASSEMBLY	1
5	XAOZZ	96906	MS51844-62	..SWAGING SLEEVE,WIRE	1
6	XAOZZ	81337	SC-B-781198	..PIN	1
7	XAOZZ	81349	MIL-C-5424	..ROPE,WIRE	V
8	XAOZZ	81337	SC-B-781199	..TAB	1
9	XAOZZ	76691	071-1-Q	..STOP,SLEEVE	1
10	PAOZZ	81337	SC-B-781204	.KEEPER,TAPPED	1
11	PAOZZ	81337	SC-C-200154	.KEEPER	2
12	PAOZZ	81337	SC-B-200153-1	.SHIM,KEEPER	V
END OF FIGURE					

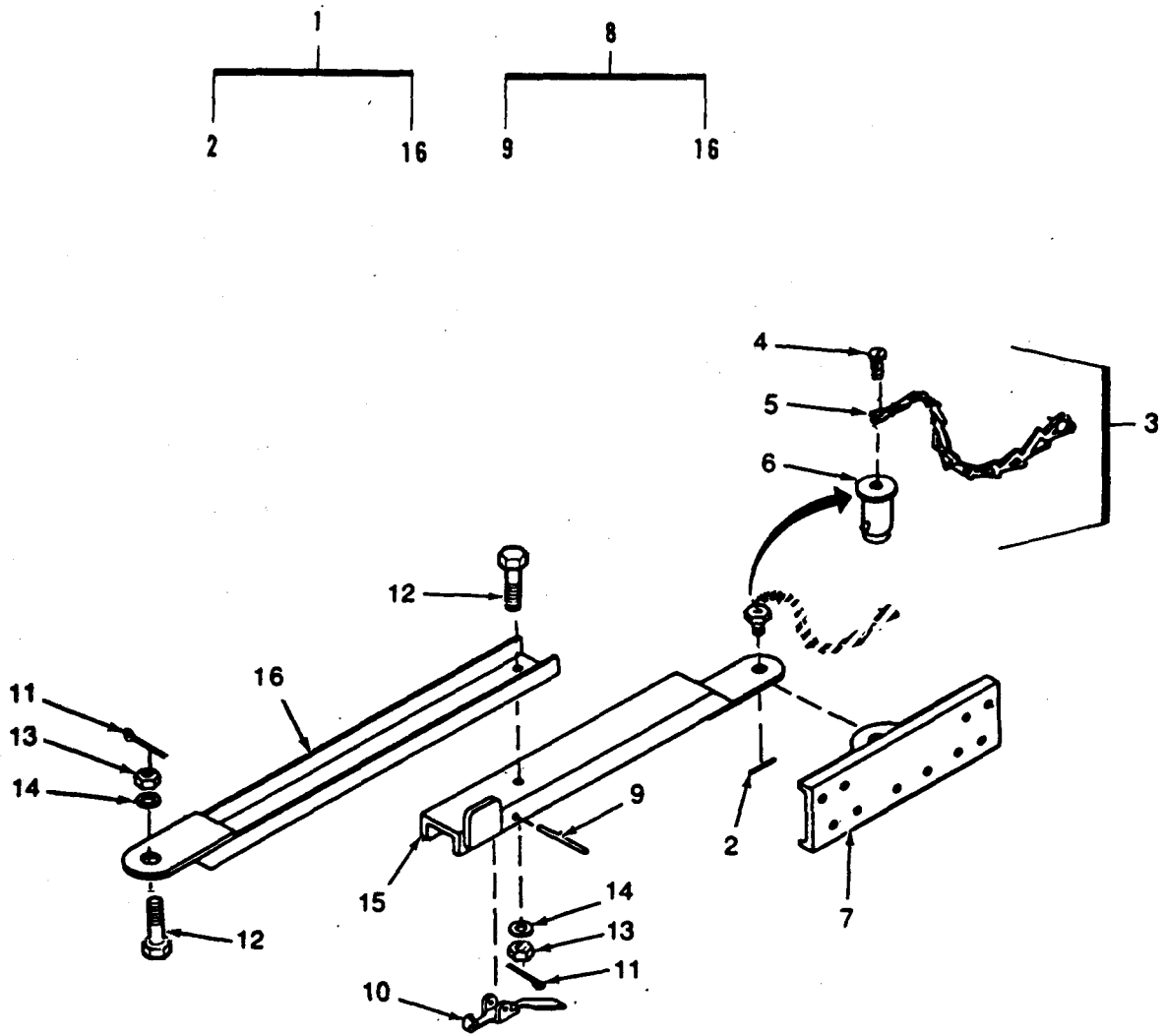

Figure 5. Door Brace Assembly

SECTION II (1)	(2)	(3)	TM10-5411-207-24P (4)	(5)	(6)
ITEM NO	SMR CODE	CAGEC	PART NUMBER	DESCRIPTION AND USABLE ON CODES (UOC)	QTY
GROUP 04 DOOR GRACE ASSEMBLY					
FIG. 5 DOOR BRACE ASSEMBLY					
1	PAOZZ	81337	SC-D-595548	DOOR BRACE ASSEMBLY	1
2	PAOZZ	96906	MS24665-285	.PIN,COTTER	1
3	XAOZZ	81337	SM-B-340027	.CHAIN & PIN ASSY	1
4	PAOZZ	96906	MS21318-41	..SCREW,DRIVE	1
5	PAOZZ	39428	53607	..CHAIN,SASH	1
6	PAOZZ	96906	MS20392-6C17	..PIN,FLAT HD	1
7	XBOZZ	81337	SM-C-340028	.BRACKET,DOOR STOP	1
8	PAOZZ	81337	SC-D-595078	.DOOR BRACE ASSEMBLY	1
9	PAOZZ	96906	MS16562-227	..PIN,SPRING	1
10	XAOZZ	81337	SC-C-595039	..CATCH,DOOR BRACE	1
11	PAOZZ	96906	MS24665-300	..PIN,COTTER	2
12	PAOZZ	88044	AN7C7	..BOLT,MACHINE	2
13	PAOZZ	81352	AN310C7	..NUT,PLAIN,CASTELLAT	2
14	PAOZZ	88044	AN960C716	..WASHER,FLAT	2
15	XAOZZ	81337	SC-C-200157	..BRACE ASSY	1
16	XAOZZ	81337	SC-C-200158	..BRACE ASSY	1
END OF FIGURE					

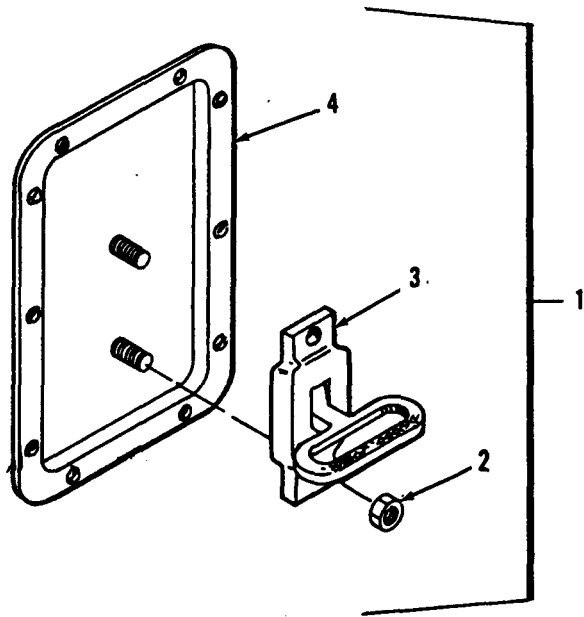

Figure 6. Pan Assembly Recessed Step

SECTION II (1)	SMR (2)	CAGEC (3)	PART (4)	DESCRIPTION AND USABLE ON CODES (UOC) (5)	QTY (6)
ITEM NO	CODE		NUMBER		
				GROUP 05 PAN ASSEMBLY RECESSED STEP	
				FIG. 6 PAN ASSEMBLY RECESSED STEP	
1	PAOOZ	19220	AL3-575709	FOLDING STEP ASSY	3
2	XBOZZ	19220	15949	.LOCKNUT	2
3	PAOZZ	19220	1-575709-50	.STEP,FOLDING	1
4	PAOZZ	19220	AL-15951	.PAN,RECESSED STEP	1
				END OF FIGURE	

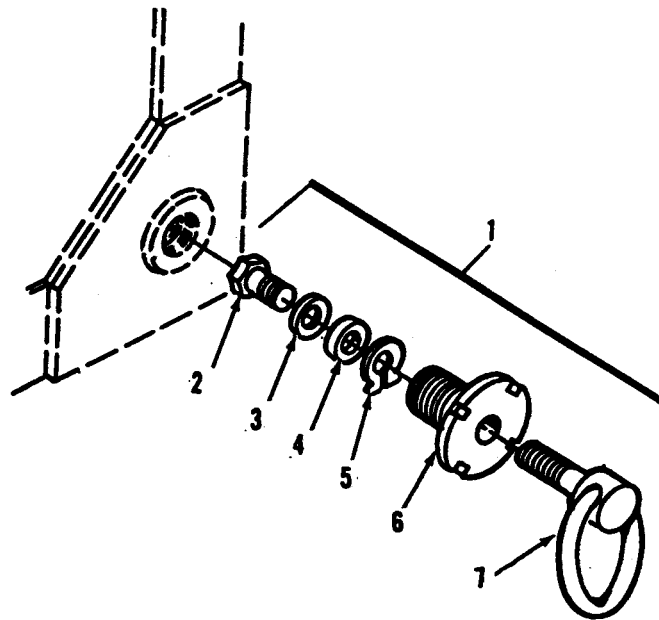

Figure 7. Towing Eye Assembly

SECTION II				TM10-5411-207-24P		
(1)	(2)	(3)	(4)	(5)		(6)
ITEM NO	SMR CODE	CAGEC	PART NUMBER	DESCRIPTION AND USABLE ON CODES (UOC)		QTY
GROUP 06 TOWING EYE ASSEMBLY						
FIG. 7 TOWING EYE ASSEMBLY						
1	PAOFF	81337	SM-C-947147	TOWING EYE ASSY		4
2	PAFZZ	81337	SM-B-947152	.SCREW,MACHINE		1
3	PAFZZ	80063	SM-B-947234	.WASHER,FLAT		1
4	PAFZZ	81337	SM-B-947151	.SPACER,RING		1
5	PAFZZ	79136	5160-98	.RING,RETAINING		1
6	PAFZZ	81337	SM-B-947149	.COLLAR,RING,THD		1
7	PAFZZ	81337	SM-C-947148	.RING & STUD ASSY		1
END OF FIGURE						

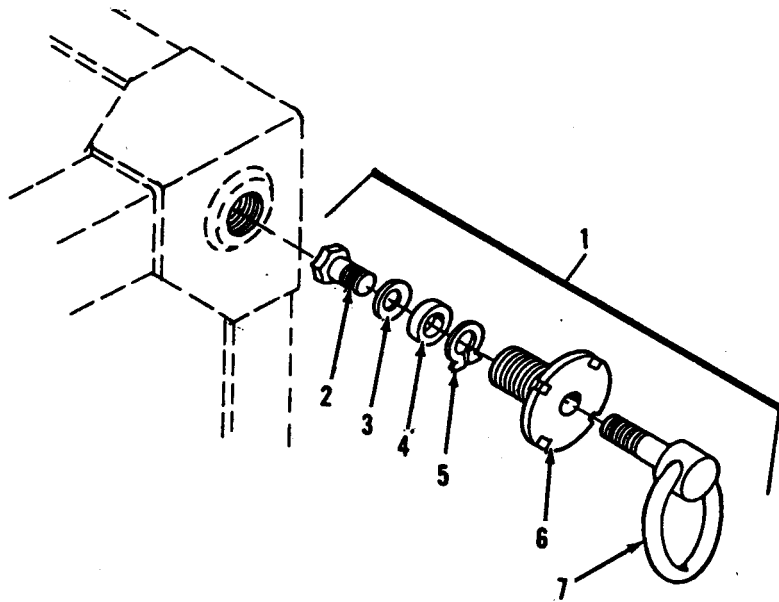

Figure 8. Lifting and Tiedown Eye Assembly

SECTION II				TM10-5411-207-24P		
(1)	(2)	(3)	(4)	(5)	(6)	
ITEM NO	SMR CODE	CAGEC	PART NUMBER	DESCRIPTION AND USABLE ON CODES (UOC)	QTY	
				GROUP 07 LIFTING AND TIEDOWN ASSEMBLY		
				FIG. 8 LIFTING AND TIEDOWN ASSEMBLY		
1	PAOFF	81337	SM-C-947176	LIFTING & TIEDOWN	4	
2	PAFZZ	81337	SM-B-947152	.SCREW,MACHINE	1	
3	PAFZZ	80063	SM-B-947234	.WASHER,FLAT	1	
4	PAFZZ	81337	SM-B-947151	.SPACER,RING	1	
5	PAFZZ	79136	5160-98	.RING,RETAINING	1	
6	PAFZZ	81337	SM-B-947149	.COLLAR,RING,THD	1	
7	PAFZZ	81337	SM-C-947177	.RING AND STUD	1	
				END OF FIGURE		

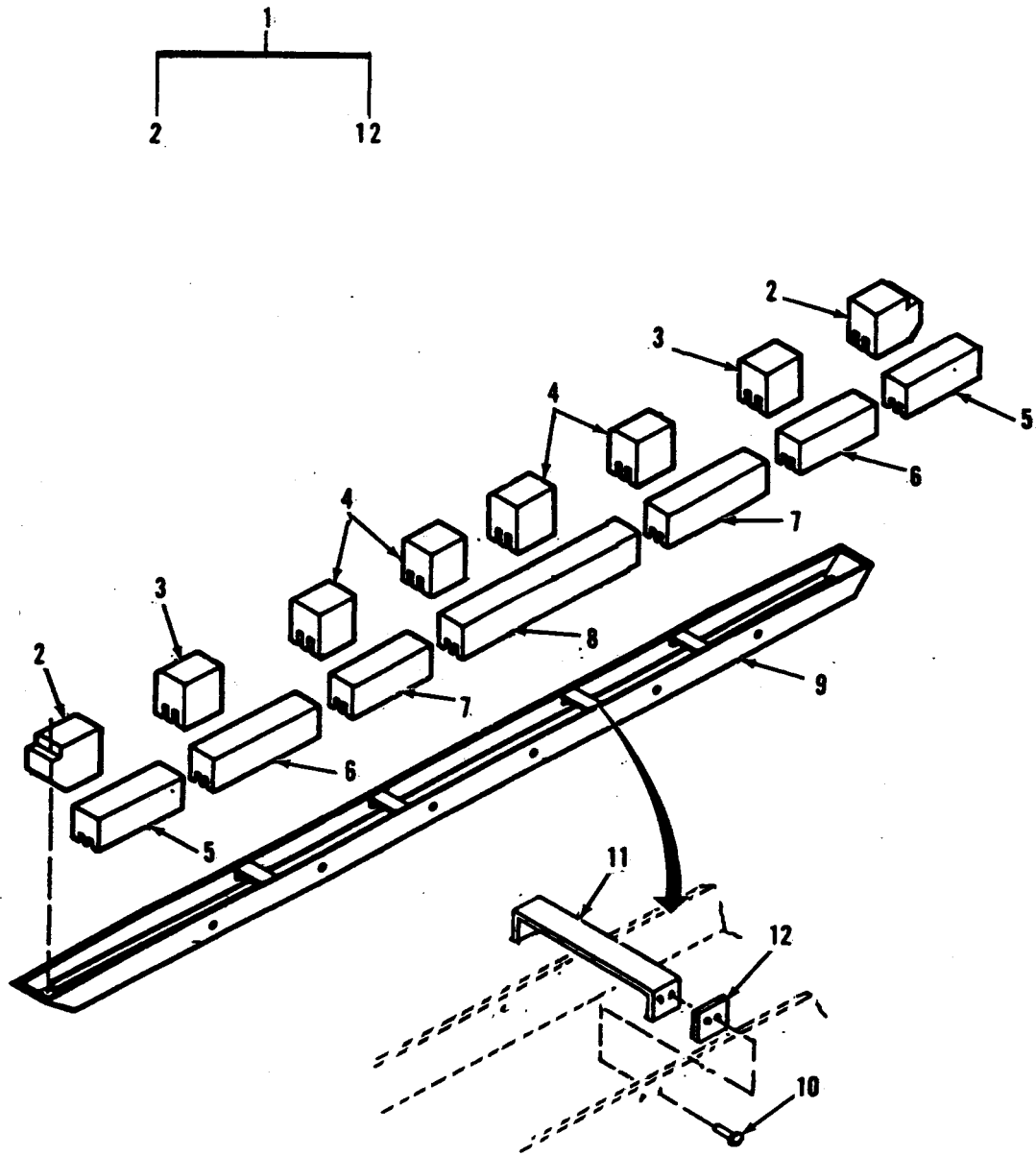

Figure 9. Skid Assembly

SECTION II				TM10-5411-207-24P	
(1)	(2)	(3)	(4)	(5)	(6)
ITEM NO	SMR CODE	CAGEC	PART NUMBER	DESCRIPTION AND USABLE ON CODES (UOC)	QTY
GROUP 08 SKID ASSEMBLY					
FIG. 9 SKID ASSEMBLY					
1	PBOOO	81337	SM-D-947238	SKID ASSEMBLY	3
2	PAOZZ	81337	SM-C-947230	.SHOCK MOUNT	2
3	PAOZZ	80063	SM-C-947237	.BUMPER, NONMETALLIC	2
4	PAOZZ	81337	SM-C-555515-3	.SHOCK MOUNT	4
5	XAOZZ	81337	SM-C-947174-5	.CORE	2
6	XAOZZ	81337	SM-C-947174-3	.CORE	2
7	XAOZZ	81337	SM-C-947174-2	.CORE	2
8	XAOZZ	81337	SM-C-947174-4	.CORE	1
9	XAOZZ	81337	SM-D-947236	.SKID RUNNER WELD	1
10	PAOZZ	80205	NAS1399D6-6	.RIVET, BLIND	16
11	XAOZZ	81337	SM-B-555506	.BRACKET, CHANNEL	4
12	XAOZZ	81337	SC-B-595498	.SHIM, LAMINATED	V
END OF FIGURE					

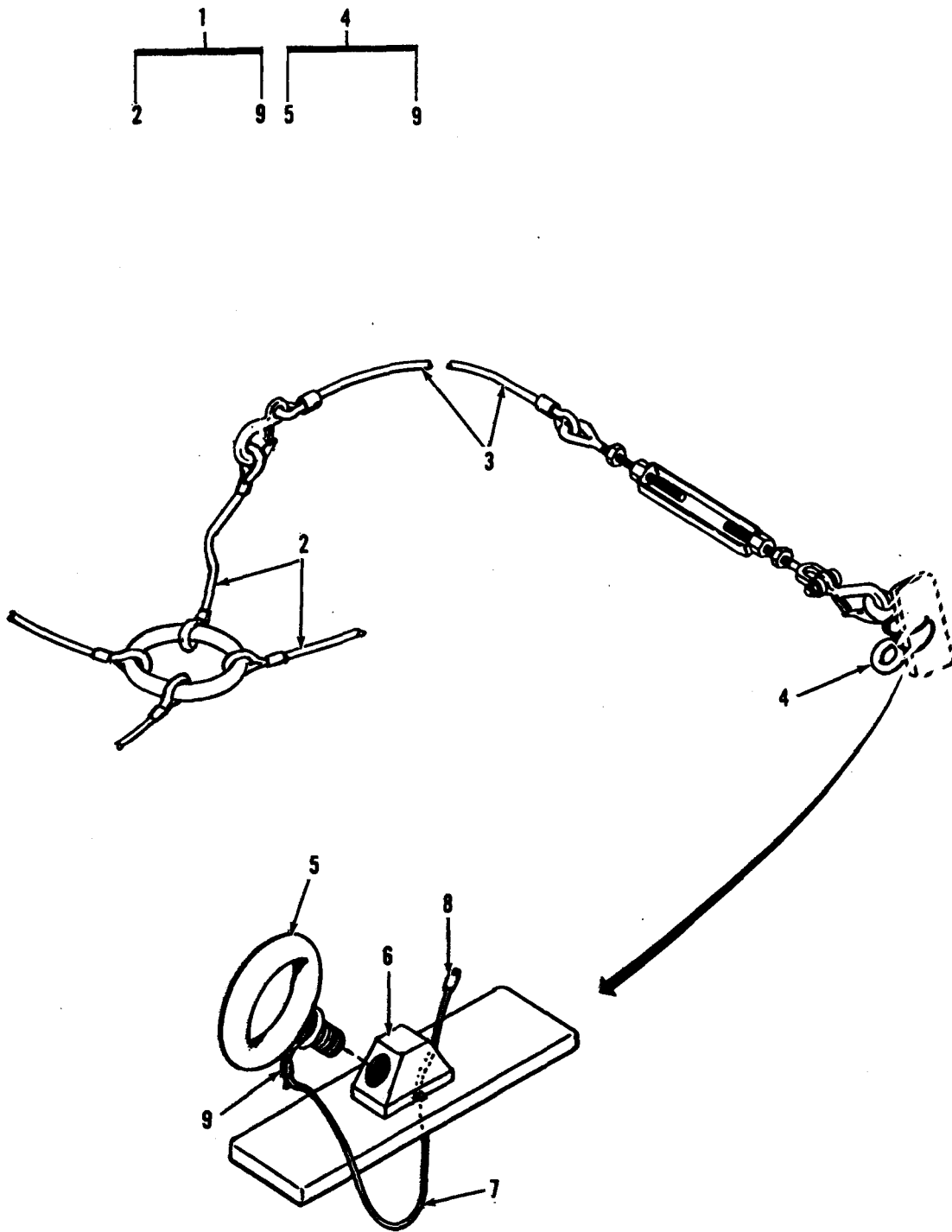

Figure 10. Hold Down Assembly

SECTION II			TM10-5411-207-24P CO1		
(1)	(2)	(3)	(4)	(5)	(6)
ITEM	SMR		PART		
NO	CODE	CAGEC	NUMBER	DESCRIPTION AND USABLE ON CODES (UOC)	QTY
				GROUP 09 HOLD DOWN ASSEMBLY	
				FIG.10 HOLD DOWN ASSEMBLY	
*	1	PA00Z 80063	SC-D-36423	SLING ASSEMBLY, VEHI	1
	2	PA0ZZ 81337	17-1-5304	.RING ASSEMBLY	1
	3	PA0ZZ 81337	SC-D-36424	.CABLE ASSY	1
*	4	PA0ZZ 80063	SC-C-595076	.PLATE AND EYEBOLT A	2
	5	PA0ZZ 80063	SC-B-595075	..BOLT, EYE	2
	6	PA0ZZ 81337	SC-D-595074	..PLATE	1
	7	XBOZZ 81337	SC-C-595076-1	..CABLE, 1/16DX17LG	2
	8	XBOZZ 76691	871-1-Q	..SLEEVE	1
	9	XBOZZ 76691	28-1-C	..SWAGING SLEEVE, WIRE	1

END OF FIGURE

**SECTION III
SPECIAL TOOLS LIST (Not Applicable)**

CROSS-REFERENCE INDEXES

NATIONAL STOCK NUMBER INDEX					
STOCK NUMBER	FIG.	ITEM	STOCK NUMBER	FIG.	ITEM
5315-00-005-0442	5	2	5310-00-807-1469	1	27
5410-00-007-5164	5	8	5340-00-836-1938	1	5
5320-00-012-0747	9	10	5315-00-846-8337	3	7
5305-00-021-3620	4	2	3940-00-846-9858	10	1
5410-00-030-6925	10	4	5310-00-869-9576	3	29
5310-00-045-3296	2	11	5320-00-874-4471	1	9
5310-00-050-6646	1	49	5310-00-883-9417	4	3
5305-00-050-9230	3	28	4010-00-889-2210	2	5
5305-00-052-7436	1	18	5410-00-919-4958	6	3
5305-00-054-6670	2	36	5320-00-932-1972	1	13
5315-00-058-9756	5	9	5410-00-933-0845	1	3
5315-00-058-9784	1	34	5310-00-934-9758	2	12
5315-00-062-5417	3	9	5320-00-956-7355	1	7
5315-00-075-5828	3	19		1	43
5320-00-081-8302	2	14	5320-00-956-7362	1	1
9330-00-107-1165	2	32	5315-00-957-2649	3	4
5320-00-117-6853	1	4	5320-00-957-3582	1	46
5340-00-118-0018	2	26	5305-00-984-7364	2	9
5340-00-143-0394	3	33	5340-00-989-4535	1	23
5310-00-145-2217	2	25	5320-01-032-6534	1	2
5310-00-167-0805	5	14	5340-01-044-0163	2	18
5310-00-167-1283	5	13	5365-01-071-9006	7	5
5365-00-173-7010	3	26		8	5
5306-00-182-1513	1	29	5340-01-082-3431	3	24
5306-00-182-1514	1	26	5310-01-097-6608	1	11
5310-00-183-4355	3	3	5340-01-114-2139	6	1
* 5999-00-196-1299	2	37B	5340-01-155-3503	1	21
5305-00-207-8253	4	1	5340-01-183-9149	9	3
5340-00-229-5747	3	10	5340-01-239-8427	4	4
5315-00-234-1863	5	11	5340-01-239-8705	3	30
5330-00-248-3847	3	16	5306-01-240-0652	10	5
5305-00-253-5622	5	4	5310-01-270-1743	7	3
5305-00-253-5625	2	4		8	3
4030-00-262-1574	2	3	5306-01-274-6069	5	12
5365-00-263-9560	3	22	5410-01-276-7663	5	1
5310-00-301-4558	3	21	5365-01-300-7150	7	4
5310-00-406-7240	3	20	5365-01-300-7150	8	4
5305-00-533-5446	1	19			
	3	32			
5306-00-543-5578	1	48			
5330-00-545-5221	2	19			
*	2	22			
*	2	23			
5310-00-595-6057	1	50			
5310-00-625-5756	1	28			
5306-00-637-8062	1	20			
5340-00-793-1099	3	6			
5340-00-794-4440	3	1			
5340-00-794-4610	3	8			
5340-00-794-4612	3	15			

CROSS-REFERENCE INDEXES

CAGEG	PART NUMBER	PART NUMBER INDEX STOCK NUMBER	FIG.	ITEM
07707	AD42H	5320-00-932-1972	1	13
07707	AD42S	5320-00-957-3582	1	46
07707	AD43H		1	41
07707	AD45H	5320-00-874-4471	1	9
07707	AD62H	5320-00-956-7362	1	1
07707	AD64H	5320-00-956-7355	1	7
			1	43
07707	AD68H	5320-01-032-6534	1	2
19220	AL-15951		6	4
19220	AL3-575709	5340-01-114-2139	6	1
19220	AL5601 1/2-51		1	8
			2	13
* 19220	AL5601 1/2-50	5340-01-044-0163	2	18
88044	AN101011	5306-00-637-8062	1	20
81352	AN310C7	5310-00-167-1283	5	13
88044	AN5C-25A	5306-00-182-1513	1	29
88044	AN5C-26A	5306-00-182-1514	1	26
88044	AN7C7	5306-01-274-6069	5	12
81352	AN960-C516L		1	30
88044	AN960C616L	5310-00-183-4355	3	3
88044	AN960C716	5310-00-167-0805	5	14
98003	H-945-SS-2-RG	5340-00-836-1938	1	5
81349	MIL-C-5424		4	7
96906	MS15795-812	5310-00-625-5756	1	28
96906	MS15795-815	5310-00-595-6057	1	50
96906	MS16208-68	5306-00-543-5578	1	48
96906	MS16562-227	5315-00-058-9756	5	9
96906	MS16562-237	5315-00-058-9784	1	34
96906	MS171526		3	2
96906	MS171528		3	11
96906	MS171659	5315-00-846-8337	3	7
96906	MS17830-10C	5310-00-406-7240	3	20
96906	MS17830-6C	5310-00-050-6646	1	49
96906	MS20392-5C23	5315-00-075-5828	3	19
96906	MS20392-5C33	5315-00-957-2649	3	4
96906	MS20392-6C17		5	6
96906	MS20470AD6-8	5320-00-117-6853	1	4
96906	MS21042-5	5310-00-807-1469	1	27
96906	MS21318-41	5305-00-253-5622	5	4
96906	MS21318-46	5305-00-253-5625	2	4
96906	MS24617-54	5305-00-052-7436	1	18
96906	MS24665-285	5315-00-005-0442	5	2
96906	MS24665-300	5315-00-234-1863	5	11
96906	MS27163-8		2	10
96906	MS29513-115	5330-00-248-3847	3	16
96906	MS35206-273	5305-00-984-7364	2	9
96906	MS35307-307	5305-00-021-3620	4	2
96906	MS35307-308	5305-00-207-8253	4	1
96906	MS35338-157	5310-00-869-9576	3	29
96906	MS35338-158	5310-00-883-9417	4	3
96906	MS35338-43	5310-00-045-3296	2	11

CROSS-REFERENCE INDEXES

CAGEG	PART NUMBER	PART NUMBER INDEX STOCK NUMBER	FIG.	ITEM
96906	MS35493-53	5305-00-533-5446	1	19
			3	32
96906	MS35649-202	5310-00-934-9758	2	12
96906	MS35674-41	5315-00-062-5417	3	9
96906	MS35914-149	5340-00-143-0394	3	33
96906	MS35914-150	5340-00-989-4535	1	23
96906	MS51844-62		4	5
96906	MS51957-45	5305-00-054-6670	2	36
96906	MS51957-64	5305-00-050-9230	3	28
80205	NAS1398D4-3		2	33
80205	NAS1398D4-4		2	30
80205	NAS1398D6-3	5320-00-081-8302	2	14
80205	NAS1398D6-5		2	17
80205	NAS1398D6-8		2	7
80205	NAS1399D4-4		2	29
80205	NAS1399D6-6	5320-00-012-0747	9	10
80205	NAS1739E4-3		2	27
81337	SC-B-200143		3	12
81337	SC-B-200144		3	13
* 80063	SC-B-200145	5365-00-263-9560	3	22
* 80063	SC-B-200146	5310-00-301-4558	3	21
81337	SC-B-200150		3	17
81337	SC-B-200151		3	18
81337	SC-B-200153-1		4	12
80063	SC-B-595073	5340-01-082-3431	3	24
80063	SC-B-595075	5306-01-240-0652	10	5
* 81337	SC-B-595079		1	15
81337	SC-B-595081		2	31
81337	SC-B-595498		9	12
81337	SC-B-781197	5340-01-239-8427	4	4
81337	SC-B-781198		4	6
81337	SC-B-781199		4	8
81337	SC-B-781204		4	10
80063	SC-C-200135	5340-01-155-3503	1	21
* 80063	SC-C-200141	5340-00-229-5747	3	10
81337	SC-C-200142		3	14
81337	SC-C-200154		4	11
81337	SC-C-200157		5	15
81337	SC-C-200158		5	16
81337	SC-C-595039		5	10
* 80063	SC-C-595076	5410-00-030-6925	10	4
81337	SC-C-595076-1		10	7
80063	SC-C-595537	5340-01-239-8705	3	30
81337	SC-D-200140	5340-00-794-4440	3	1
81337	SC-D-200140-8		3	25
* 80063	SC-D-36423	3940-00-846-9858	10	1
81337	SC-D-36424		10	3
* 80063	SC-D-563202GRI	5340-00-793-1099	3	6
81337	SC-D-563202GRII		3	5
81337	SC-D-595074		10	6
81337	SC-D-595078	5410-00-007-5164	5	8

CROSS-REFERENCE INDEXES

CAGEG	PART NUMBER	PART NUMBER INDEX STOCK NUMBER	FIG.	ITEM
81337	SC-D-595548	5410-01-276-7663	5	1
* 80063	SM-B-113596-1	5340-00-794-4610	3	8
81337	SM-B-162197-2		1	31
81337	SM-B-162200		3	27
81337	SM-B-317129		1	37
81337	SM-B-340027		5	3
81337	SM-B-340031		1	16
81337	SM-B-450432		2	34
81337	SM-B-450435		2	35
* 81337	SM-B-450436-1	5999-00-196-1299	2	37B
* 80063	SM-B-450447	5340-00-118-0018	2	26
81337	SM-B-450448		2	28
81337	SM-B-450465		2	15
81337	SM-B-508785		1	35
81337	SM-B-555506		9	11
81337	SM-B-555572		2	16
* 81337	SM-B-564670-3		2	19A
* 81337	SM-B-564670-4		2	22A
81337	SM-B-615256		1	25
80063	SM-B-615259-1	5365-00-173-7010	3	26
81337	SM-B-615259-2		3	23
81337	SM-B-947146-3		1	32
81337	SM-B-947149		7	6
			8	6
81337	SM-B-947151	5365-01-300-7150	7	4
			8	4
81337	SM-B-947152		7	2
			8	2
81337	SM-B-947157		1	45
81337	SM-B-947164		1	10
81337	SM-B-947228		1	12
81337	SM-B-947229		1	15
81337	SM-B-947231		1	22
80063	SM-B-947234	5310-01-270-1743	7	3
			8	3
81337	SM-B-947239		1	17
* 80063	SM-C-113597	5340-00-794-4612	3	15
80063	SM-C-165382	5410-00-933-0845	1	3
81337	SM-C-165383		1	6
81337	SM-C-165466		1	14
81337	SM-C-317057		1	33
81337	SM-C-340028		5	7
81337	SM-C-450441		2	2
81337	SM-C-450443		2	8
80063	SM-C-450466	9330-00-107-1165	2	32
* 81337	SM-C-450478		2	37A
81337	SM-C-508783		1	36
81337	SM-C-508784		1	38
81337	SM-C-555515-3		9	4
81337	SM-C-564811		1	24

CROSS-REFERENCE INDEXES

CAGEG	PART NUMBER	PART NUMBER INDEX STOCK NUMBER	FIG.	ITEM
* 81337	SM-C-564839	5330-00-545-5221	2	19
			2	22
			2	23
81337	SM-C-615255		3	31
81337	SM-C-615262-1		2	38
81337	SM-C-615262-2		2	39
81337	SM-C-615263		2	6
81337	SM-C-615264		2	37
81337	SM-C-947147		7	1
81337	SM-C-947148		7	7
81337	SM-C-947155		1	42
81337	SM-C-947156		1	47
81337	SM-C-947169-1		1	53
81337	SM-C-947169-2		1	54
81337	SM-C-947169-3		1	55
81337	SM-C-947169-4		1	56
81337	SM-C-947174-2		9	7
81337	SM-C-947174-3		9	6
81337	SM-C-947174-4		9	8
81337	SM-C-947174-5		9	5
81337	SM-C-947176		8	1
81337	SM-C-947177		8	7
81337	SM-C-947230		9	2
80063	SM-C-947237	5340-01-183-9149	9	3
81337	SM-D-450462		2	21
81337	SM-D-947154		1	40
81337	SM-D-947166		2	1
81337	SM-D-947167		2	20
81337	SM-D-947235		1	51
81337	SM-D-947236		9	9
81337	SM-D-947238		9	1
03481	SS8B120	5310-01-097-6608	1	11
03481	S31B125CS1		1	57
03481	S31B425CS1		1	39
76691	071-1-Q		4	9
02751	1-4-31	5310-00-145-2217	2	25
19220	1-575709-50	5410-00-919-4958	6	3
70892	13AN	4030-00-262-1574	2	3
70892	13S	4010-00-889-2210	2	5
19220	15949		6	2
81337	17-1-5304		10	2
72962	21NTU-040		2	24
76691	28-1-C		10	9
79136	5160-98	5365-01-071-9006	7	5
			8	5
39428	53607		1	5
70276	56517		1	52
01943	8173-1		1	44
76691	871-1-Q		10	8

CROSS-REFERENCE INDEXES

FIG.	ITEM	FIGURE AND ITEM NUMBER INDEX		PART NUMBER
		STOCK NUMBER	CAGEC	
1	1	5320-00-956-7362	07707	AD62H
1	2	5320-01-032-6534	07707	AD68H
1	3	5410-00-933-0845	80063	SM-C-165382
1	4	5320-00-117-6853	96906	MS20470AD6-8
1	5	5340-00-836-1938	98003	H-945-SS-2-RG
1	6		81337	SM-C-165383
1	7	5320-00-956-7355	07707	AD64H
1	8		19220	AL5601 1/2-51
1	9	5320-00-874-4471	07707	AD45H
1	10		81337	SM-B-947164
1	11	5310-01-097-6608	03481	SS8B120
1	12		81337	SM-B-947228
1	13	5320-00-932-1972	07707	AD42H
1	14		81337	SM-C-165466
1	15		81337	SM-B-947229
1	15		81337	SM-B-595079
1	16		81337	SM-B-340031
1	17		81337	SM-B-947239
1	18	5305-00-052-7436	96906	MS24617-54
1	19	5305-00-533-5446	96906	MS35493-53
1	20	5306-00-637-8062	88044	AN101011
1	21	5340-01-155-3503	80063	SC-C-200135
1	22		81337	SM-B-947231
1	23	5340-00-989-4535	96906	MS35914-150
1	24		81337	SM-C-564811
1	25		81337	SM-B-615256
1	26	5306-00-182-1514	88044	AN5C-26A
1	27	5310-00-807-1469	96906	MS21042-5
1	28	5310-00-625-5756	96906	MS15795-812
1	29	5306-00-182-1513	88044	AN5C-25A
1	30		81352	AN960-C516L
1	31		81337	SM-B-162197-2
1	32		81337	SM-B-947146-3
1	33		81337	SM-C-317057
1	34	5315-00-058-9784	96906	MS16562-237
1	35		81337	SM-B-508785
1	36		81337	SM-C-508783
1	37		81337	SM-B-317129
1	38		81337	SM-C-508784
1	39		03481	S31B425CS1
1	40		81337	SM-D-947154
1	41		07707	AD43H
1	42		81337	SM-C-947155
1	43	5320-00-956-7355	07707	AD64H
1	44		01943	8173-1
1	45		81337	SM-B-947157
1	46	5320-00-957-3582	07707	AD42S
1	47		81337	SM-C-947156
1	48	5306-00-543-5578	96906	MS16208-68
1	49	5310-00-050-6646	96906	MS17830-6C
1	50	5310-00-595-6057	96906	MS15795-815

CROSS-REFERENCE INDEXES

FIG.	ITEM	FIGURE AND ITEMNUMBER INDEX		PART NUMBER
		STOCK NUMBER	CAGEC	
1	51		81337	SM-D-947235
1	52		70276	56517
1	53		81337	SM-C-947169-1
1	54		81337	SM-C-947169-2
1	55		81337	SM-C-947169-3
1	56		81337	SM-C-947169-4
1	57		03481	S31B125CS1
2	1		81337	SM-D-947166
2	2		81337	SM-C-450441
2	3	4030-00-262-1574	70892	13AN
2	4	5305-00-253-5625	96906	MS21318-46
2	5	4010-00-889-2210	70892	13S
2	6		81337	SM-C-615263
2	7		80205	NAS1398D6-8
2	8		81337	SM-C-450443
2	9	5305-00-984-7364	96906	MS35206-273
2	10		96906	MS27163-8
2	11	5310-00-045-3296	96906	MS35338-43
2	12	5310-00-934-9758	96906	MS35649-202
2	13		19220	AL5601 1/2-51
2	14	5320-00-081-8302	80205	NAS1398D6-3
2	15		81337	SM-B-450465
2	16		81337	SM-B-555572
2	17		80205	NAS1398D6-5
* 2	18	5340-01-044-0163	19220	AL5601 1/2-50
* 2	19	5330-00-545-5221	81337	SM-C-564839
* 2	19A		81337	SM-B-564670-3
2	20		81337	SM-D-947167
2	21		81337	SM-D-450462
2	22		81337	SM-C-564839
* 2	22A		81337	SM-B-564670-4
2	23		81337	SM-C-564839
2	24		72962	21NTU-040
2	25	5310-00-145-2217	02751	1-4-31
* 2	26	5340-00-118-0018	80063	SM-B-450447
2	27		80205	NAS1739E4-3
2	28		81337	SM-B-450448
2	29		80205	NAS1399D4-4
2	30		80205	NAS1398D4-4
2	31		81337	SC-B-595081
2	32	9330-00-107-1165	80063	SM-C-450466
2	33		80205	NAS1398D4-3
2	34		81337	SM-B-450432
2	35		81337	SM-B-450435
2	36	5305-00-054-6670	96906	MS51957-45
2	37		81337	SM-C-615264
* 2	37A		81337	SM-C-450478
* 2	37B	5999-00-196-1299	81337	SM-B-450436-1
2	38		81337	SM-C-615262-1
2	39		81337	SM-C-615262-2

CROSS-REFERENCE INDEXES

FIGURE AND ITEM NUMBER INDEX

FIG	ITEM	STOCK NUMBER	CAGEC	PART NUMBER
3	1	5340-00-794-4440	81337	SC-D-200140
3	2		96906	MS171526
3	3	5310-00-183-4355	88044	AN960C616L
3	4	5315-00-957-2649	96906	MS20392-5C33
3	5		81337	SC-D-563202GR11
* 3	6	5340-00-793-1099	80063	SC-D-563202GRI
3	7	5315-00-846-8337	96906	MS171659
* 3	8	5340-00-794-4610	80063	SM-B-113596-1
3	9	5315-00-062-5417	96906	MS35674-41
* 3	10	5340-00-229-5747	80063	SC-C-200141
3	11		96906	MS171528
3	12		81337	SC-B-200143
3	13		81337	SC-B-200144
3	14		81337	SC-C-200142
* 3	15	5340-00-794-4612	80063	SM-C-113597
3	16	5330-00-248-3847	96906	MS29513-115
3	17		81337	SC-B-200150
3	18		81337	SC-B-200151
3	19	5315-00-075-5828	96906	MS20392-5C23
3	20	5310-00-406-7240	96906	MS17830-10C
* 3	21	5310-00-301-4558	80063	SC-B-200146
* 3	22	5365-00-263-9560	80063	SC-B-200145
3	23		81337	SM-B-615259-2
3	24	5340-01-082-3431	80063	SC-B-595073
3	25		81337	SC-D-200140-8
3	26	5365-00-173-7010	80063	SM-B-615259-1
3	27		81337	SM-B-162200
3	28	5305-00-050-9230	96906	MS51957-64
3	29	5310-00-869-9576	96906	MS35338-157
3	30	5340-01-239-8705	80063	SC-C-595537
3	31		81337	SM-C-615255
3	32	5305-00-533-5446	96906	MS35493-53
3	33	5340-00-143-0394	96906	MS35914-149
4	1	5305-00-207-8253	96906	MS35307-308
4	2	5305-00-021-3620	96906	MS35307-307
4	3	5310-00-883-9417	96906	MS35338-158
4	4	5340-01-239-8427	81337	SC-B-781197
4	5		96906	MS51844-62
4	6		81337	SC-B-781198
4	7		81349	MIL-C-5424
4	8		81337	SC-B-781199
4	9		76691	071-1-Q
4	10		81337	SC-B-781204
4	11		81337	SC-C-200154
4	12		81337	SC-B-200153-1
5	1	5410-01-276-7663	81337	SC-D-595548
5	2	5315-00-005-0442	96906	MS24665-285
5	3		81337	SM-B-340027
5	4	5305-00-253-5622	96906	MS21318-41
5	5		39428	53607
5	6		96906	MS20392-6C17

CROSS-REFERENCE INDEXES

FIGURE AND ITEM NUMBER INDEX				
FIG.	ITEM	STOCK NUMBER	CAGEC	PART NUMBER
5	7		81337	SM-C-340028
5	8	5410-00-007-5164	81337	SC-D-595078
5	9	5315-00-058-9756	96906	MS16562-227
5	10		81337	SC-C-595039
5	11	5315-00-234-1863	96906	MS24665-300
5	12	5306-01-274-6069	88044	AN7C7
5	13	5310-00-167-1283	81352	AN310C7
5	14	5310-00-167-0805	88044	AN960C716
5	15		81337	SC-C-200157
5	16		81337	SC-C-200158
6	1	5340-01-114-2139	19220	AL3-575709
6	2		19220	15949
6	3	5410-00-919-4958	19220	1-575709-50
6	4		19220	AL-15951
7	1		81337	SM-C-947147
7	2		81337	SM-B-947152
7	3	5310-01-270-1743	80063	SM-B-947234
7	4	5365-01-300-7150	81337	SM-B-947151
7	5	5365-01-071-9006	79136	5160-98
7	6		81337	SM-B-947149
7	7		81337	SM-C-947148
8	1		81337	SM-C-947176
8	2		81337	SM-B-947152
8	3	5310-01-270-1743	80063	SM-B-947234
8	4	5365-01-300-7150	81337	SM-B-947151
8	5	5365-01-071-9006	79136	5160-98
8	6		81337	SM-B-947149
8	7		81337	SM-C-947177
9	1		81337	SM-D-947238
9	2		81337	SM-C-947230
9	3	5340-01-183-9149	80063	SM-C-947237
9	4		81337	SM-C-555515-3
9	5		81337	SM-C-947174-5
9	6		81337	SM-C-947174-3
9	7		81337	SM-C-947174-2
9	8		81337	SM-C-947174-4
9	9		81337	SM-D-947236
9	10	5320-00-012-0747	80205	NAS1399D6-6
9	11		81337	SM-B-555506
9	12		81337	SC-B-595498
* 10	1	3940-00-846-9858	80063	SC-D-36423
10	2		81337	17-1-5304
10	3		81337	SC-D-36424
* 10	4	5410-00-030-6925	80063	SC-C-595076
10	5	5306-01-240-0652	80063	SC-B-595075
10	6		81337	SC-D-595074
10	7		81337	SC-C-595076-1
10	8		76691	871-1-Q
10	9		76691	28-1-C

By Order of the Secretary of the Army:

GORDON R. SULLIVAN
General, United States Army
Chief of Staff

Official:

PATRICIA P. HICKERSON
Brigadier General, United States Army
The Adjutant General

DISTRIBUTION:

To be distributed in accordance with DA Form 12-25E, (qty rqr bl no. 2745)..

RECOMMENDED CHANGES TO EQUIPMENT TECHNICAL PUBLICATIONS



THEN... JOT DOWN THE DOPE ABOUT IT ON THIS FORM. CAREFULLY TEAR IT OUT. FOLD IT AND DROP IT IN THE MAIL!

SOMETHING WRONG WITH THIS PUBLICATION?

FROM: (PRINT YOUR UNIT'S COMPLETE ADDRESS)

PFC JOHN DOE
COA, 3d ENGINEER BN
FT. LEONARDWOOD, MD 63108

DATE SENT

PUBLICATION NUMBER

TM 10-5411-207-24P

PUBLICATION DATE

19 Aug 1991

PUBLICATION TITLE

SHELTER, ELECTRICAL EQUIPMENT

BE EXACT. PIN-POINT WHERE IT IS

PAGE NO	PARA-GRAPH	FIGURE NO	TABLE NO
6	2-1 a		
B1		4-3	
125	line 20		

IN THIS SPACE TELL WHAT IS WRONG AND WHAT SHOULD BE DONE ABOUT IT:

In line 6 of paragraph 2-1a the manual states the engine has 6 Cylinders. The engine on my set only has 4 Cylinders. Change the manual to show 4 Cylinders.

Callout 16 on figure 4-3 is pointing at a bolt. In key to figure 4-3, item 16 is called a skin - Please correct one or the other.

I ordered a gasket, item 19 on figure B-16 by NSN 2 910-05-762-3001. I got a gasket but it doesn't fit. Supply says I got what I ordered, so the NSN is wrong. Please give me a good NSN

PRINTED NAME, GRADE OR TITLE, AND TELEPHONE NUMBER

JOHN DOE, PFC (268) 317-7111

SIGN HERE

JOHN DOE

DA FORM 1 JUL 79 2028-2

PREVIOUS EDITIONS ARE OBSOLETE.
DRSTS-M Overprint 1, 1 Nov 80

P.S.--IF YOUR OUTFIT WANTS TO KNOW ABOUT YOUR RECOMMENDATION MAKE A CARBON COPY OF THIS AND GIVE IT TO YOUR HEADQUARTERS.

TEAR ALONG PERFORATED LINE

FILL IN YOUR
UNIT'S ADDRESS



FOLD BACK

DEPARTMENT OF THE ARMY

OFFICIAL BUSINESS

COMMANDER
U.S. ARMY TROOP SUPPORT COMMAND
ATTN: AMSTR-MMTS
4300 GOODFELLOW BOULEVARD
ST. LOUIS, MO 63120-1798

TEAR ALONG PERFORATED LINE

The Metric System and Equivalents

Linear Measure

1 centimeter = 10 millimeters = .39 inch
 1 decimeter = 10 centimeters = 3.94 inches
 1 meter = 10 decimeters = 39.37 inches
 1 dekameter = 10 meters = 32.8 feet
 1 hectometer = 10 dekameters = 328.08 feet
 1 kilometer = 10 hectometers = 3,280.8 feet

Weights

1 centigram = 10 milligrams = .15 grain
 1 decigram = 10 centigrams = 1.54 grains
 1 gram = 10 decigrams = .035 ounce
 1 dekagram = 10 grams = .35 ounce
 1 hectogram = 10 dekagrams = 3.52 ounces
 1 kilogram = 10 hectograms = 2.2 pounds
 1 quintal = 100 kilograms = 220.46 pounds
 1 metric ton = 10 quintals = 1.1 short tons

Liquid Measure

1 centiliter = 10 milliliters = .34 fl. ounce
 1 deciliter = 10 centiliters = 3.38 fl. ounces
 1 liter = 10 deciliters = 33.81 fl. ounces
 1 dekaliter = 10 liters = 2.64 gallons
 1 hectoliter = 10 dekaliters = 26.42 gallons
 1 kiloliter = 10 hectoliters = 264.18 gallons

Square Measure

1 sq. centimeter = 100 sq. millimeters = .155 sq. inch
 1 sq. decimeter = 100 sq. centimeters = 15.5 sq. inches
 1 sq. meter (centare) = 100 sq. decimeters = 10.76 sq. feet
 1 sq. dekameter (are) = 100 sq. meters = 1,076.4 sq. feet
 1 sq. hectometer (hectare) = 100 sq. dekameters = 2.47 acres
 1 sq. kilometer = 100 sq. hectometers = .386 sq. mile

Cubic Measure

1 cu. centimeter = 1000 cu. millimeters = .06 cu. inch
 1 cu. decimeter = 1000 cu. centimeters = 61.02 cu. inches
 1 cu. meter = 1000 cu. decimeters = 35.31 cu. feet

Approximate Conversion Factors

To change	To	Multiply by	To change	To	Multiply by
inches	centimeters	2.540	ounce-inches	newton-meters	.007062
feet	meters	.305	centimeters	inches	.394
yards	meters	.914	meters	feet	3.280
miles	kilometers	1.609	meters	yards	1.094
square inches	square centimeters	6.451	kilometers	miles	.621
square feet	square meters	.093	square centimeters	square inches	.155
square yards	square meters	.836	square meters	square feet	10.764
square miles	square kilometers	2.590	square meters	square yards	1.196
acres	square hectometers	.405	square kilometers	square miles	.386
cubic feet	cubic meters	.028	square hectometers	acres	2.471
cubic yards	cubic meters	.765	cubic meters	cubic feet	35.315
fluid ounces	milliliters	29.573	cubic meters	cubic yards	1.308
pints	liters	.473	milliliters	fluid ounces	.034
quarts	liters	.946	liters	pints	2.113
gallons	liters	3.785	liters	quarts	1.057
ounces	grams	28.349	liters	gallons	.264
pounds	kilograms	.454	grams	ounces	.035
short tons	metric tons	.907	kilograms	pounds	2.205
pound-feet	newton-meters	1.356	metric tons	short tons	1.102
pound-inches	newton-meters	.11296			

Temperature (Exact)

°F	Fahrenheit	5/9 (after	Celsius	°C
	temperature	subtracting 32)	temperature	

PIN: 068514-001